



January 31, 2022

PUBLIC OUTREACH MEETING

Onaga Trail Pedestrian Improvement Project

Town Project No. 7005-2020; ATP No. 5466(025)

and

Little League Drive Pedestrian Improvement Project

Town Project No. 8970-2020; ATP No. 5466(024)



SUMMARY

- The 1st Public Outreach Meeting was held on September 16, 2021.
- Since then:
 - Town staff met with numerous property owners to address different issues:
 - Driveways
 - Curb and gutter
 - Mailboxes
 - Chain link fences
 - Project Plans are 95% developed



ONAGA TRAIL PEDESTRIAN IMPROVEMENT PROJECT

Town Project No. 7005-2020

ATP No. 5466(025)



ONAGA TRAIL PEDESTRIAN IMPROVEMENT PROJECT

Project Description

- The project is located on Onaga Trail between Acoma Trail and approximately Grand Avenue.
- It is divided in two (2) segments due to existing constraints to meet the General Plan designation. (Arterial – 4 Lane Divided – 100' ROW)
- Both segments would have full width pavement, **curb and gutter, handicap ramps, and sidewalk on both sides of Onaga Trail.**
- This would result in sidewalks on both sides of Onaga Trail, between Sage Avenue and Acoma Trail.



ONAGA TRAIL PEDESTRIAN IMPROVEMENT PROJECT

Proposed Improvements

1st Segment - Onaga Street, between Acoma Trail and Church Street

ACOMA TRAIL TO CHURCH ST.

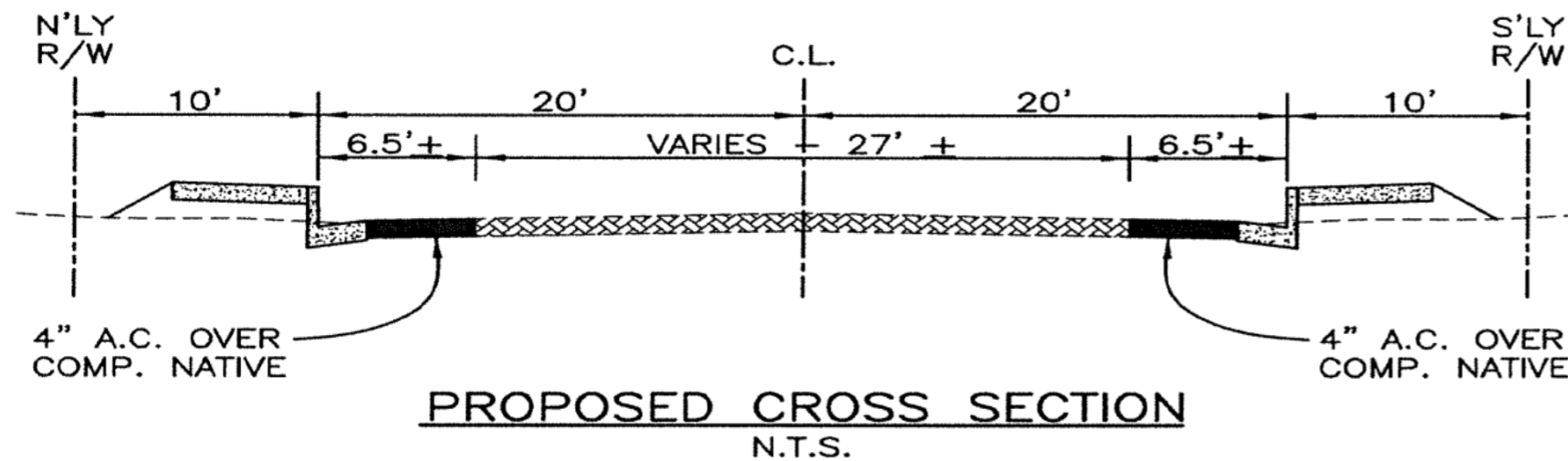
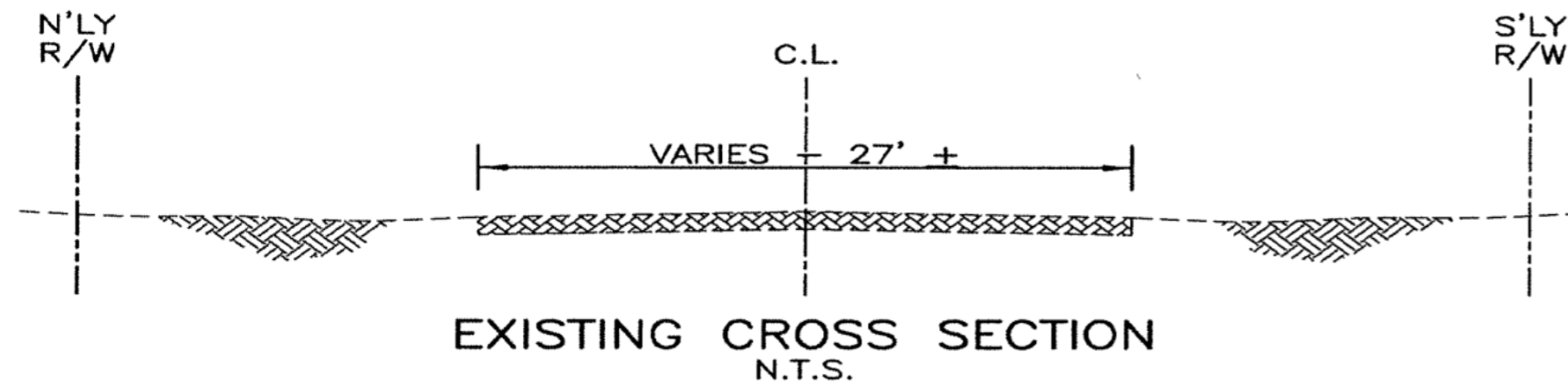

Improved to a local road standard of 60 foot right of way.

No additional right of way would be required.

Improvements can be constructed with minimal impact to the existing residences.



ONAGA TRAIL PEDESTRIAN IMPROVEMENT PROJECT

2nd Segment - Onaga Street, between Church Street and approximately Grand Avenue

CHURCH ST. TO SAGE AVE.

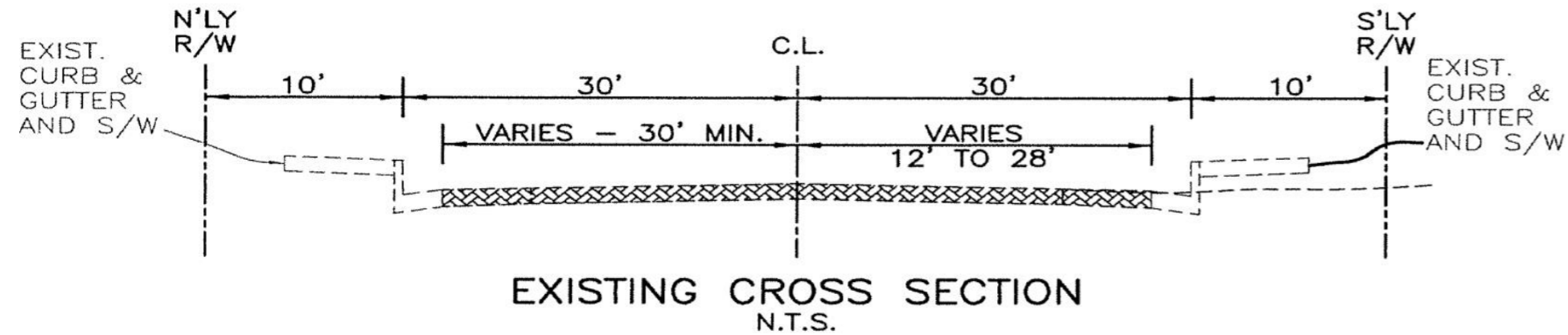

Improved within the existing 80 foot right of way.

Eighty (80') feet will allow for:

- four lanes of traffic,
- a painted median with turn pockets,
- no on-street parking, and
- no shoulder.



ONAGA TRAIL PEDESTRIAN IMPROVEMENT PROJECT

Project Budget

- Project Total Cost (Estimated)= **\$ 1,663,295.00**
- Active Transportation Program (ATP) Cycle 3 will fund a total of **\$776,000**
- Local match and non-reimbursement eligible costs are funded through a transfer of funds from Fund 524, Measure I.



ONAGA TRAIL PEDESTRIAN IMPROVEMENT PROJECT





LITTLE LEAGUE DRIVE PEDESTRIAN IMPROVEMENT PROJECT

Town Project No. 8970-2020

ATP No. 5466(024)



LITTLE LEAGUE DRIVE PEDESTRIAN IMPROVEMENT PROJECT

Project Description

- The project is located on Little League Drive between Palm Avenue and Sage Avenue.
- The Project consists of constructing curb and gutter, sidewalk, handicap ramps, driveways, and signing and striping.
- **Majority of the work will occur on the south side of the roadway.**
- No widening of the road will occur in locations with existing curb and gutter. However, curb ramps at the intersections may need to be installed/retrofitted.



LITTLE LEAGUE DRIVE PEDESTRIAN IMPROVEMENT PROJECT

Proposed Improvements

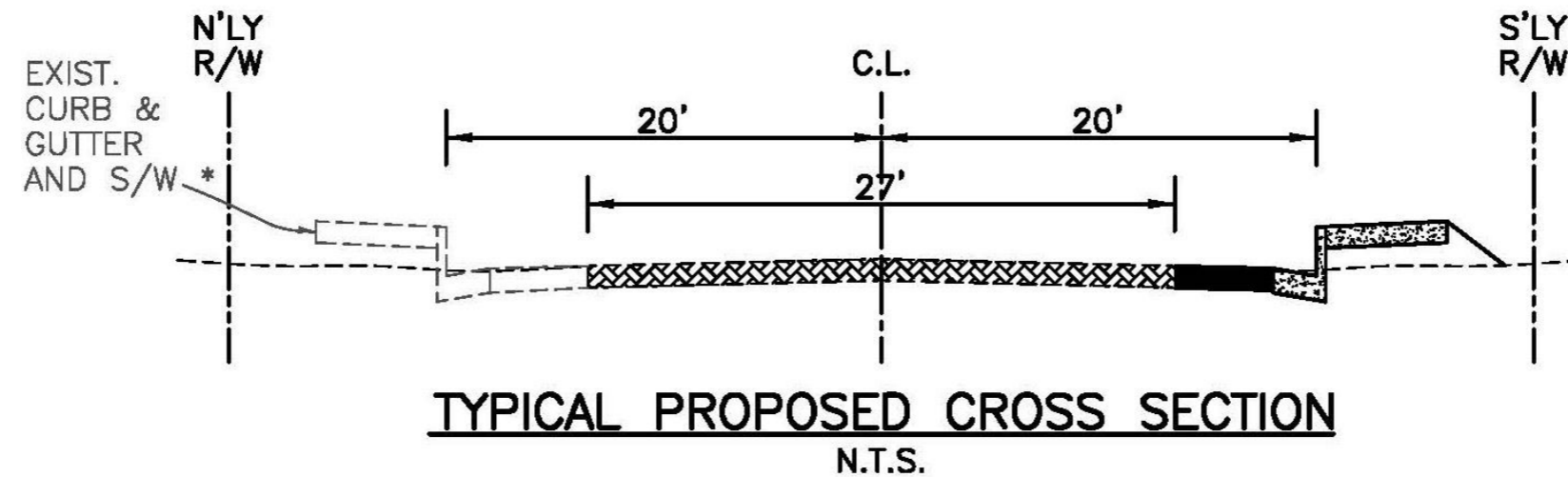
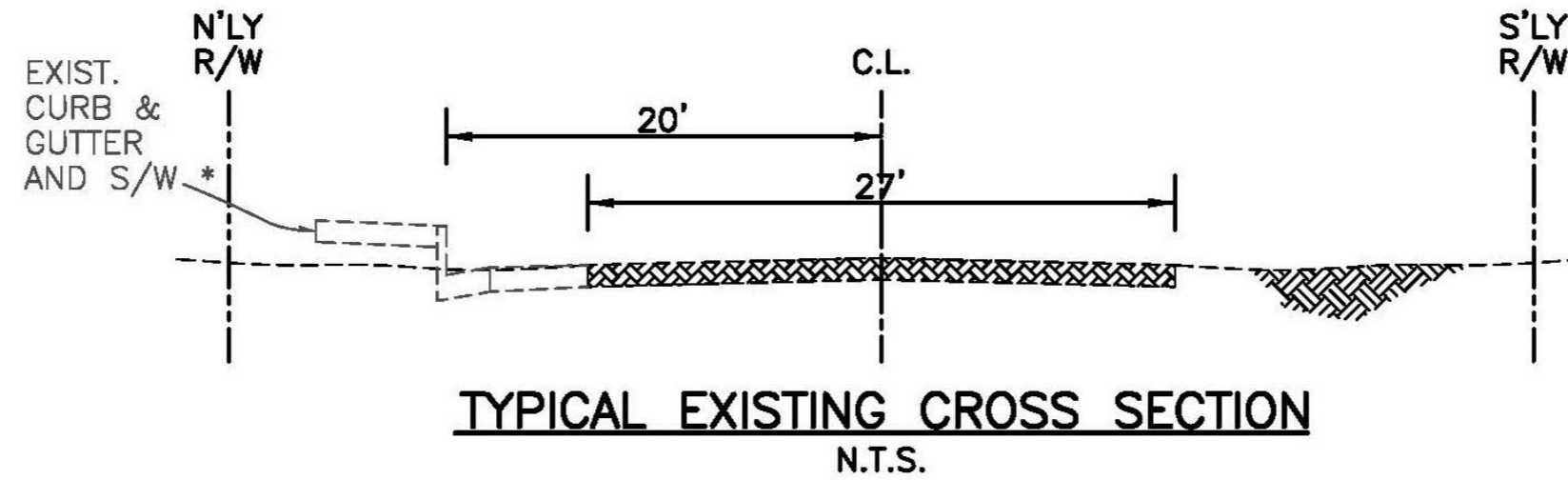



LITTLE LEAGUE DRIVE PEDESTRIAN IMPROVEMENT PROJECT

Project Budget

- Project Total Cost (Estimated)= **\$ 957,750.00**
- Active Transportation Program (ATP) Cycle 3 will fund a total of **\$622,400**
- Local match and non-reimbursement eligible costs are funded through a transfer of funds from Fund 524, Measure I.



LITTLE LEAGUE DRIVE PEDESTRIAN IMPROVEMENT PROJECT





ATP Projected Construction Schedule

Bid the project: Estimated April/May through June/July 2022

Construction: Estimated August through October 2022

*** SR-62 Asphalt Overlay may offset the schedule.**

****All subject to Caltrans approvals and Caltrans timelines.**



Next Steps

- Public Outreach
- Joshua Tree Relocation/Removal
- Complete Plans and Specifications
- Caltrans Authorization to bid
- Town Council approval to bid project
- Bid the project
- Award Contract
- Estimated Construction August Through October 2022.



Questions (Following Public Comment)