

TOWN OF YUCCA VALLEY
PLANNING COMMISSION MEETING



The Mission of the Town of Yucca Valley is to provide a government that is responsive to the needs and concerns of its diverse citizenry and ensures a safe and secure environment while maintaining the highest quality of life.

**TUESDAY
APRIL 08, 2014
6:00 p.m.**

**YUCCA VALLEY COMMUNITY CENTER, YUCCA ROOM
57090 - 29 PALMS HIGHWAY
YUCCA VALLEY, CALIFORNIA 92284**

*** * * ***

PLANNING COMMISSION MEMBERS

*Tim Humphreville, Chairman
Vickie Bridenstine, Vice Chairman
Jeff Drozd, Commissioner
Warren Lavender, Commissioner
Steve Whitten, Commissioner*

AGENDA

MEETING OF THE TOWN OF YUCCA VALLEY PLANNING COMMISSION 6:00 P.M., TUESDAY, APRIL 08, 2014

The Town of Yucca Valley complies with the Americans with Disabilities Act of 1990. If you require special assistance to attend or participate in this meeting, please call the Town Clerk's office at (760) 369-7209 at least 48 hours prior to the meeting.

If you wish to comment on any subject on the agenda, or any subject not on the agenda during public comments, please fill out a card and give it to the Planning Commission secretary. The Chair will recognize you at the appropriate time. Comment time is limited to 3 minutes.

CALL TO ORDER:

ROLL CALL: Vickie Bridenstine, Vice Chairman
Jeff Drozd, Commissioner
Tim Humphreville, Chairman
Warren Lavender, Commissioner
Steve Whitten, Commissioner

PLEDGE OF ALLEGIANCE

APPROVAL OF AGENDA

Action: Move by _____ 2nd by _____ Voice Vote _____.

PUBLIC COMMENTS

In order to assist in the orderly and timely conduct of the meeting, the Planning Commission takes this time to consider your comments on items of concern, which are not on the agenda. When you are called to speak, please state your name and community of residence. Please limit your comments to three minutes or less. Inappropriate behavior, which disrupts or otherwise impedes the orderly conduct of the meeting, will result in forfeiture of your public comment privileges. The Planning Commission is prohibited by State law from taking action or discussing items not included on the printed agenda.

PUBLIC HEARING

**1. VARIANCE, V 02-14
ROSS DRESS FOR LESS**

A request to allow the installation of a 258 square foot wall sign where 125 square feet of wall signage is allowed.

The project was reviewed under the California Environmental Quality Act (CEQA). The project is exempt from CEQA under section 15301, Existing Facilities.

RECOMMENDATION: That the Planning Commission denies Variance, V 01-14 based upon the findings contained within the staff report.

Action: Moved by _____ 2nd by _____ Voice Vote _____

**2. DEVELOPMENT CODE AMENDMENT, DCA 07-13 ARTICLE 3
CEQA EXEMPTION, SECTION 15061**

Proposed amendment to Title 9, Yucca Valley Development Code adding Article 3, Chapter 9.30 thru Chapter 9.46, General Development Standards, providing standards for Dedications and Infrastructure Improvements, Landscaping, Parking, Performance Standards, Property Maintenance, Sign Regulations, Soil Erosion and Dust Control, Temporary Special Events, Temporary Uses, Surface Mining and Land Reclamation, Trip Reduction, Accessory Energy Systems, Wireless Communication Facilities, and Cemeteries

RECOMMENDATION: That the Planning Commission:

- A. Finds that the project is exempt from CEQA in accordance with Section 15061 (b)(3) of the California Environmental Quality Act. The proposed amendment to revise the Town's Permitting Procedures regulations has no potential to impact the environment. The proposed amendment does not alter the existing requirements that specific development projects must comply with the provisions of the California Environmental Quality Act. Development Code Amendment, DCA 06-03 meets the exemption criteria which states "that if an activity is covered by the general rule that CEQA applies only to projects which have the potential for causing a significant effect on the environment and where it can be seen with certainty that there is no possibility that the activity in question may have a significant effect on the environment, the activity is not subject to CEQA"
- B. Recommends that the Town Council adopts the Ordinance and repeals Municipal Code Sections 41.151 thru 41.1569 and Development Code Sections 84.0701 thru 84.0740, 87.0201 thru 87.220, 87.0401 thru 87.0405, 87.0505, 87.0601 thru 87.0645, 87.0901 thru 87.0940, 88.0805 thru 88.0810, 810.0101 thru 810.0135, 810.0201 thru 810.0275, and 9.75.010 thru 9.75.130,

Action: Moved by _____ 2nd by _____ Voice Vote _____

CONSENT AGENDA: All items listed on the consent calendar are considered to be routine matters or are considered formal documents covering previous Planning Commission instruction. The items listed on the consent calendar may be enacted by one motion and a second. There will be no separate discussion of the consent calendar items unless a member of the Planning Commission or Town Staff requests discussion on specific consent calendar items at the beginning of the meeting. Public requests to comment on consent calendar items should be filed with the Planning Commission Secretary before the consent calendar is called

1. MINUTES

A request that the Planning Commission approves as submitted the minutes of the meeting held on March 25, 2014.

Action: Moved by _____ 2nd by _____ Voice Vote _____

STAFF REPORTS AND COMMENTS:

FUTURE AGENDA ITEMS:

COMMISSIONER REPORTS AND REQUESTS:

Commissioner Drozd
Commissioner Lavender
Commissioner Whitten
Vice Chairman Bridenstine
Chairman Humphreville

ANNOUNCEMENTS:

The next regular meeting of the Yucca Valley Planning Commission will be held on Tuesday, April 27, 2014

ADJOURN

Planning Commission: April 08, 2014
TOWN OF YUCCA VALLEY
COMMUNITY DEVELOPMENT DEPARTMENT
PLANNING DIVISION STAFF REPORT
ROSS DRESS FOR LESS

Case: VARIANCE, V 01-14 ROSS
THE PROJECT IS EXEMPT FROM CEQA UNDER SECTION 15301,
EXISTING FACILITIES

Request: A REQUEST TO ALLOW THE INSTALLATION OF A 258 SQUARE
FOOT WALL SIGN WHERE 125 SQUARE FEET OF WALL SIGNAGE IS
ALLOWED.

Applicant: ROSS STORES, INC
5130 HACIENDA DRIVE
DUBLIN, CA 94568

Property Owner:
NETREIT, INC
1282 PACIFIC OAKS PL
ESCONDIDO, CA 92029

Representative:
ALL AROUND NEON
53-840 AVENIDA OBREGON
LA QUINTA, CA 92253

Location: THE PROJECT IS LOCATED AT 57646 29 PALMS HIGHWAY AND IS
IDENTIFIED AS APN 595-271-38.

Existing General Plan Land Use Designation:
THE SITE IS DESIGNATED AS COMMERCIAL (C) WITH A CORRIDOR
RESIDENTIAL OVERLAY.

Existing Zoning Designation:
THE SITE IS DESIGNATED AS NEIGHBORHOOD COMMERCIAL (C-N).

Surrounding General Plan Land Use Designations:
NORTH: COMMERCIAL (C) WITH A CORRIDOR RESIDENTIAL OVERLAY
SOUTH: COMMERCIAL (C) WITH A CORRIDOR RESIDENTIAL OVERLAY
WEST: COMMERCIAL (C) WITH A CORRIDOR RESIDENTIAL OVERLAY
EAST: COMMERCIAL (C) WITH A CORRIDOR RESIDENTIAL OVERLAY

Division Approvals:
Engineering _____ Building & Safety _____ Public Works _____

Surrounding Zoning Designations:

NORTH: NEIGHBORHOOD COMMERCIAL (C-N)
SOUTH: GENERALCOMMERCIAL(C-G)
WEST: NEIGHBORHOOD COMMERCIAL (C-N)
EAST: NEIGHBORHOOD COMMERCIAL (C-N)

Surrounding Land Use:

NORTH: VACANT LAND
SOUTH: RETAIL, VACANT LAND
WEST: RETAIL
EAST: TIRE SALES & REPAIR

CALIFORNIA ENVIRONMENTAL QUALITY ACT (CEQA):

THE PROJECT WAS REVIEWED UNDER THE CALIFORNIA ENVIRONMENTAL QUALITY ACT (CEQA). THE PROJECT IS EXEMPT FROM CEQA UNDER SECTION 15301, EXISTING FACILITIES.

RECOMMENDATIONS:

VARIANCE 01-14: That the Planning Commission denies Variance, V 01-14 based upon the findings contained within the staff report.

Project Planner: Diane Olsen, Planning Technician

Reviewed by: Shane Stueckle, Deputy Town Manager

Appeal Information:

Actions by the Planning Commission, including any finding that a negative declaration be adopted, may be appealed to the Town Council within 10 calendar days. Appeal Application filing and processing information may be obtained from the Planning Division of the Community Development Department. Per Section 83.030145 of the Development Code, minor modifications may be approved by the Planning Division if it is determined that the changes would not affect the findings prescribed in Section 83.030140 of the Development Code, Required Findings, and that the subject of the proposed changes were not items of public controversy during the review and approval of the original permit, including modifications to phasing schedules for the project.

I. GENERAL INFORMATION

PROJECT DESCRIPTION: The applicant is requesting approval of a variance to allow the installation of a 258 square foot wall sign where 125 square feet of wall signage is allowed.

LOCATION: The project is located at 57646 29 Palms Highway and is identified as APN 595-271-38

PROJECT SYNOPSIS:

SITE COVERAGE

PROJECT AREA:	1.67 acres
BUILDING AREA:	17,640 square feet
PHASED CONSTRUCTION:	None
FLOOD ZONE:	Map 8120, Zone X, areas determined to be outside the 0.2% annual chance floodplain
ALQUIST PRIOLO ZONE:	No, Yucca Valley North shows no Alquist-Priolo Special Study areas.
OFF-SITE IMPROVEMENTS REQ:	None
COMMUNITY FACILITIES DISTRICT:	No
RIGHT-OF-WAY DEDICATION REQ:	None
UTILITY UNDERGROUNDING:	No
AIRPORT INFLUENCE AREA:	Located in the transitional surface area.
TRAILS & BIKE LANE MASTER PLAN:	No facilities on or adjacent to the project
PUBLIC FACILITY MASTER PLAN:	No facilities on or adjacent to the project.

PARKS AND RECREATION MASTER PLAN:	No public facilities are identified for this site.
MASTER PLAN OF DRAINAGE:	No facilities on or adjacent to the project.
HI DESERT WATER DISTRICT WASTE-WATER PHASE:	Phase 1
STREET LIGHTS:	No
SPECIFIC PLAN/ PLANNED DEVELOPMENT AREA:	No
FUTURE PLANNING COMMISSION ACTION REQUIRED:	None
FUTURE TOWN COUNCIL ACTION REQUIRED:	None, unless appealed

II. PROJECT ANALYSIS

ENVIRONMENTAL CONSIDERATIONS: The project was reviewed under the California Environmental Quality Act (CEQA). The project is exempt from CEQA under section 15301, Existing Facilities.

ADJACENT LAND USES: The project is located within an existing commercial center which includes a grocery store, tire sales and repair facility, and other small retail shops.

SITE CHARACTERISTICS: The property is a 1.67 acre, relatively flat site that is constructed with a 17,640 square foot building and required parking, located within an existing commercial center.

DISCUSSION: The applicant is requesting a variance to allow a 258 square foot wall sign where only 125 square feet of wall signage is allowed. The applicant is also proposing to install a sign on the existing freestanding sign.

Pursuant to Section 87.07122(b)(1)(A) of the Development Code, allowable square footage for wall signs is based upon one square foot of signage per one lineal foot of lease space. The building frontage for the property in question is 125' linear feet, therefore 125 square feet of signage is allowed. The applicant is requesting approval for 258 square foot of wall signage. This request is for an additional 133 square feet or approximately an additional 107% of signage.

The intent of the sign regulations is to protect the viewsheds and aesthetic values of the community by ensuring that signage is clear, consistent and compatible with surrounding neighborhoods and the rural desert character of the Town, and to promote the community's appearance by regulating the design, character and scale of signs.

State law and the Town's Development Code are specific in the criteria for the approval of a variance. Variances can only be applied when special circumstances or conditions, such as size, shape, topography or location apply to a property which would make the strict application of the Development Code's standards impractical or physically impossible. As a result of these criteria, the findings for a Variance are also very specific, as discussed later in the staff report.

The project is located within an existing commercial center that includes a grocery store, tires sales and repair facility, a small pizza restaurant, a pool hall and several small retail stores. Each business that has been issued a sign permit pursuant to the current regulations has been in compliance and no variances have been issued for signs within the commercial center. The property in question fronts on 29 Palms Hwy and there are no physical or topographical barriers that obstruct the view of the location. Recent projects in the vicinity such as the Warren Vista Center and Rite Aid, the Yucca Valley Ford /Chrysler, Napa, Desert Oasis Healthcare and Starbucks have all recently installed signage that conforms to the current sign regulations.

CONCLUSION: The proposed variance is not consistent with the Development Code based upon the required findings. The project was reviewed under the California Environmental Quality Act (CEQA). The project is exempt from CEQA under section 15301, Existing Facilities.

FINDINGS

1. Will the granting of the variance be materially detrimental to other land uses in the area, or will it interfere with solar energy systems?

The granting of the variance may be detrimental to other properties in the area, because the signage as proposed will be considerably larger than what is allowed per code and considerably larger than what other businesses would be permitted to install. The sign is 6 feet in height and 43 feet in length and the sign will appear massive and out of character with neighboring properties, which conform to the Sign Ordinance. The granting of the variance will have no impact on solar energy systems, either now or in the future.

2. Are there exceptional circumstances associated with this property?

The project site is relatively flat and fully developed. The site is not unusually shaped and has good visibility to the highway. The wall sign for the previous tenant of the property was 98 square feet. There are no circumstances identified by staff which would support the granting of the variance in this case.

3. Would the strict application of the sign ordinance put undue limitations on this property?

No, the sign ordinance applies to all properties in Town. The signage on the surrounding properties conforms to the Sign Ordinance.

4. Is the variance compatible and consistent with the Development Code?

No, the variance is incompatible with the Purpose and Intent of the Sign Ordinance, which states " to protect the general public health, safety, welfare, viewsheds, and other aesthetic values of the community by ensuring that signage is clear, consistent and compatible with surrounding neighborhoods and the rural desert character of the Town; assure the implementation of community design standards consistent with the General Plan, promote the community's appearance by regulating the design character, location typed quality of materials scale, color illumination and maintenance of signs"

Attachments:

1. Standard Exhibits
2. Application materials
3. Photos

TOWN OF YUCCA VALLEY

PROJECT NO: VARIANCE, V 01-14 ROSS

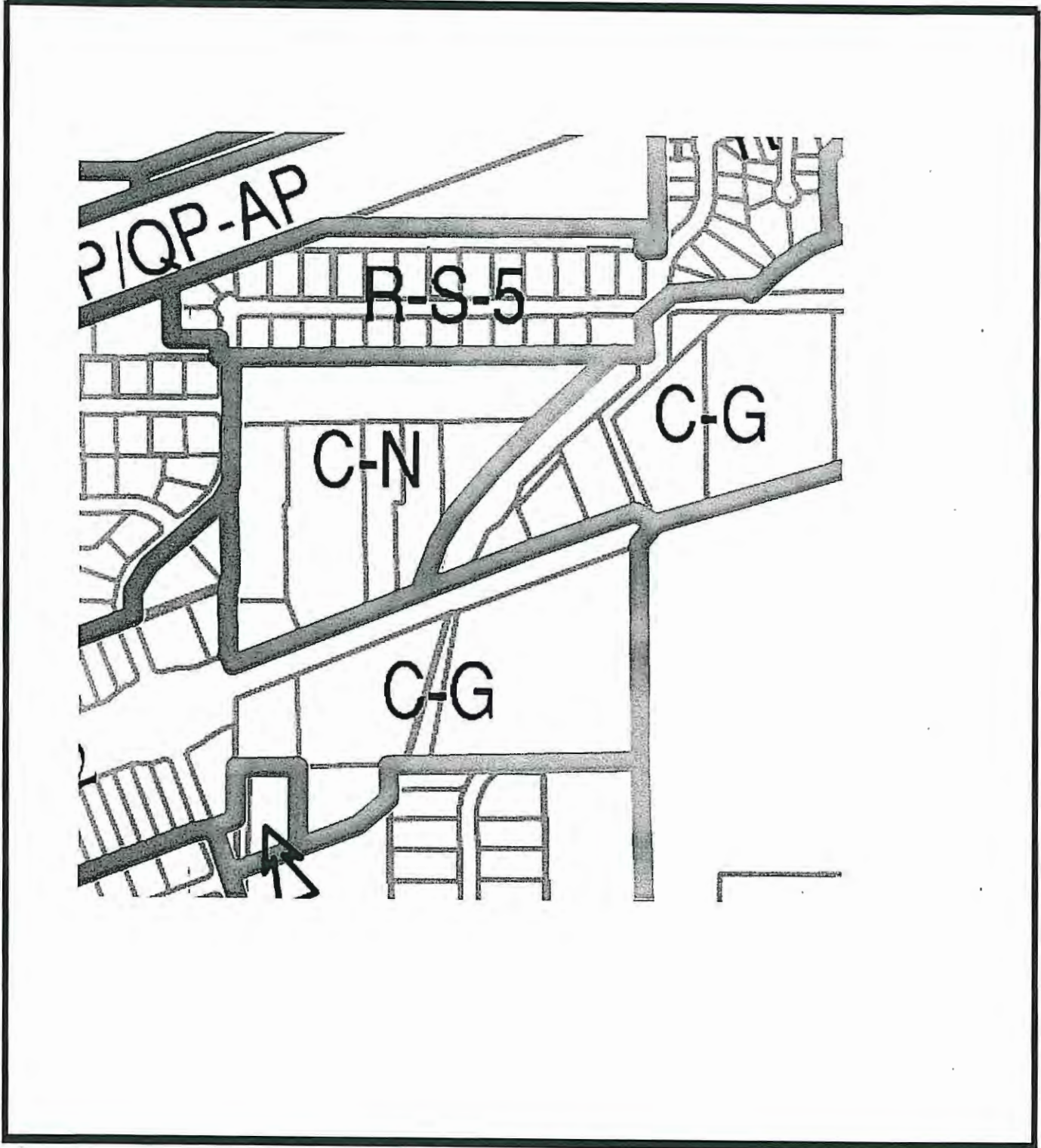

ZONING MAP

TOWN OF YUCCA VALLEY

PROJECT NO: VARIANCE, V 01-14 ROSS



AERIAL PHOTO

TOWN OF YUCCA VALLEY

PROJECT NO: VARIANCE, V 01-14 ROSS

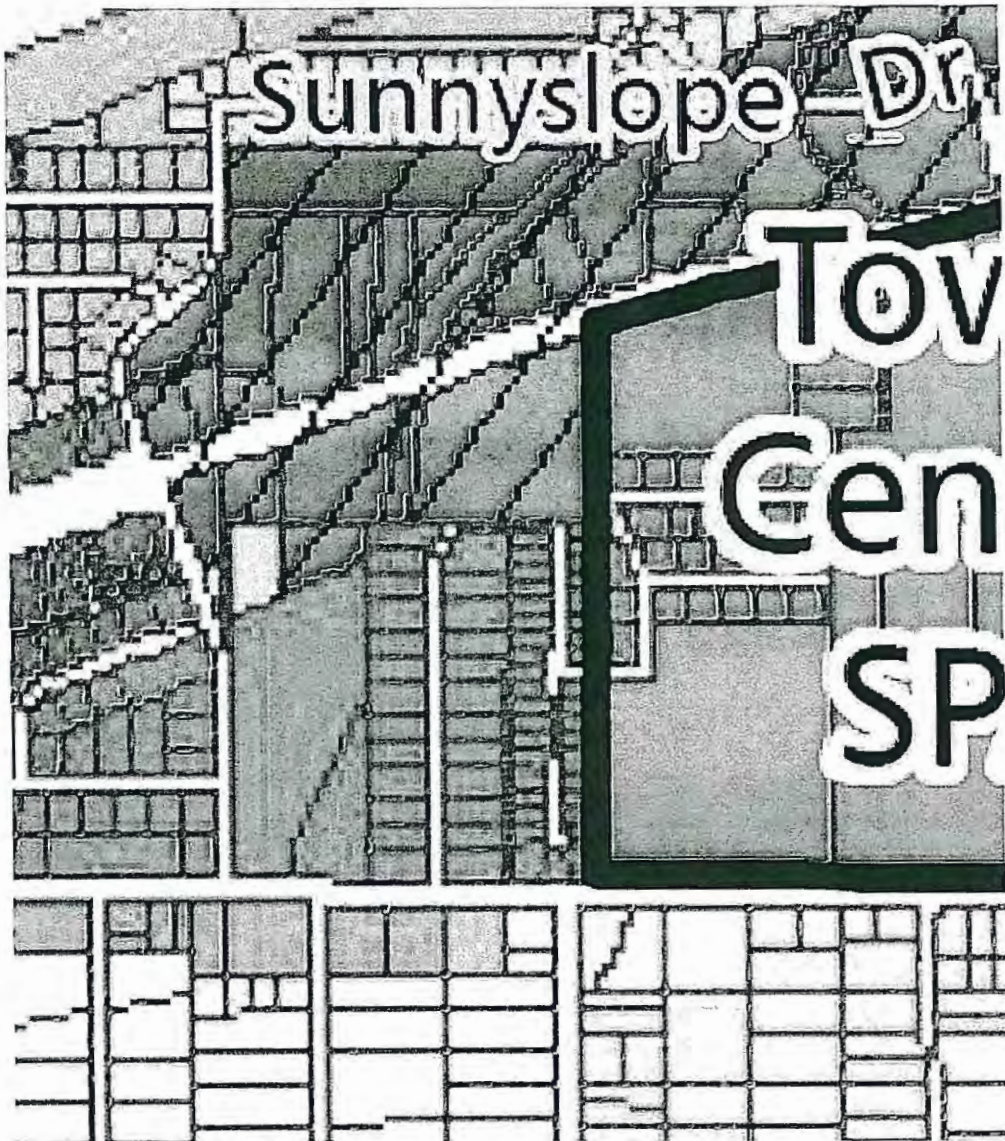

GENERAL PLAN LAND USE MAP

TOWN OF YUCCA VALLEY

PROJECT NO: VARIANCE, V 01-14 ROSS

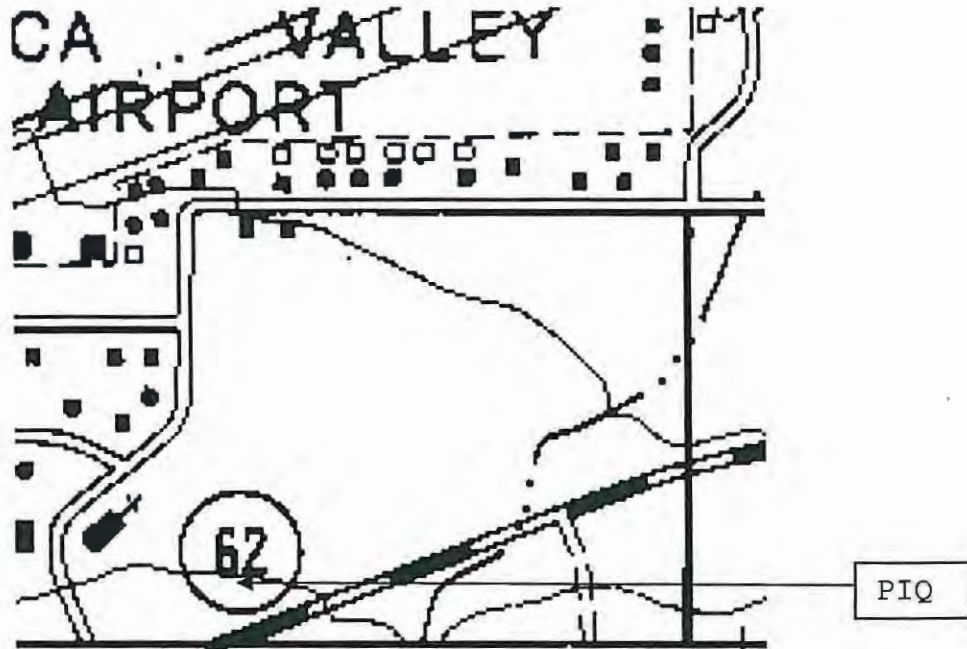

ALQUIST PRIOLO MAP-YV NORTH

TOWN OF YUCCA VALLEY

PROJECT NO: VARIANCE, V 01-14 ROSS

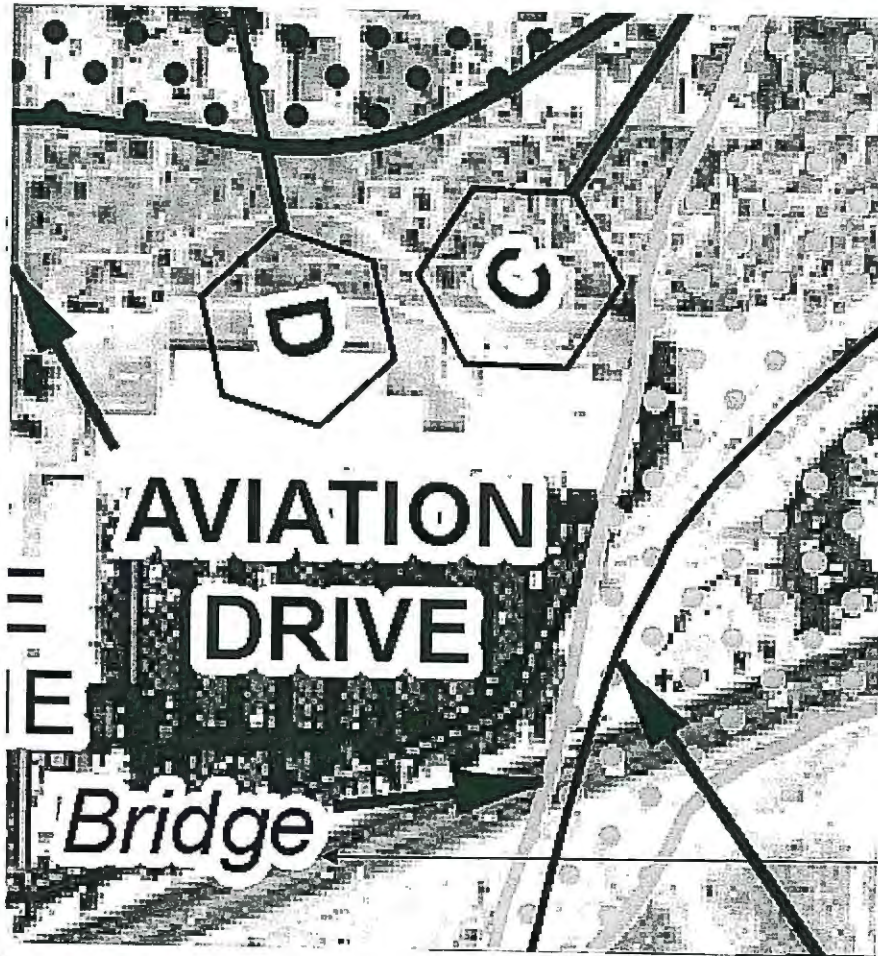

FEMA FLOOD MAP-8120



Variance Application

[X] Minor | | Major

Date Received 02/18/14
by D. OLSEN
865
Case # V-01-14

General Information

APPLICANT ROSS STORES, INC. Phone 925.965.4900 fax 925.965.4910
Mailing Address 5130 HACIENDA DR. Email jackson@ross.com
City DUBLIN, CA 94568 State Zip
REPRESENTATIVE ALL AROUND NEON Phone 760.899.5173 Fax
Mailing Address 53840 AVENIDA OBERON Email tanner@zlamundineonstudios.com
PROPERTY OWNER NETREIT, INC Phone 760.471.8536 Fax 760.471.0399
Mailing Address 1282 PACIFIC OAKS PL. Email jkatz@netreit.com
City ESCONDIDO State CA Zip 92029

Project Information

Project address or location JOSHUA VILLAGE S/C, NE 29 PALMS HWY. & AIRWAY AVE.
Assessor Parcel Number(s) 0595-271-38-0-000
Description of variance being requested TO EXCEED THE ALLOWABLE SIGN AREA
FOR NEW ROSS DRESS FOR LESS STORE

Applicant Signature Allen C. Allen AUTHORIZED AGENT FOR ROSS STORES, INC.
Property Owner Signature [Signature]

Town of Yucca Valley
Community Development Department
Planning Division
58928 Business Center Dr
Yucca Valley, CA 92284
760.369-6575 Fax 760.228-0084

Owner/Applicant Authorization

Applicant/Representative: I/We have reviewed this completed application and the attached material. The information included with this application is true and correct to the best of my/our knowledge. I/We further understand that the Town may not approve the application as submitted, and may set conditions of approval. Further, I/We understand that all documents, maps, reports, etc. submitted with this application are deemed to be public records. This application does not guarantee approval or constitute a building permit application.

Signed: Allen S. Allen
Date: 21 Jan 14

Property Owner: I/We certify that I/We are presently the legal owner(s) of the above described property (if the undersigned is different from the legal property owner, a letter of authorization must accompany the form). Further, I/We acknowledge the filing of this application and certify that all of the above information is true and accurate. I/We understand that I/We are responsible for ensuring compliance with conditions of approval. I/We hereby authorize the Town of Yucca Valley and/or its designated agent(s) to enter onto the subject property to confirm the location of existing conditions and proposed improvements including compliance with applicable Town Code Requirements. Further, I/We understand that all documents, maps, reports, etc. submitted with this application are deemed to be public records. This application does not guarantee approval or constitute a building permit application. I am hereby authorizing

_____ to act as my agent and is further authorized to sign any and all documents on my behalf.

Signed: [Signature]
Dated: 1/22/14

Town of Yucca Valley
Community Development Department
Planning Division
58928 Business Center Dr
Yucca Valley, CA 92284
760 369-6575 Fax 760 228-0084

www.yucca-valley.com

Letter of Justification
Statement of Hardship and Unique Circumstances

Ross Dress For Less
Joshua Village Shopping Center
NEC 29 Palms Hwy. & Airway Ave.
Yucca Valley, CA

Background:

Ross Stores, Inc. currently operates 6 Ross Dress For Less stores in the Inland Empire area. These stores have proven to be an asset to the communities they serve. Opening the new Ross Dress For Less store in Yucca Valley is evidence of Ross' plans to partner with the City, but they find that they need to bolster their identity by increasing the signage entitlements dictated by the City's zoning ordinance. Therefore, as agents of Ross Stores, Inc., we are applying for a variance for a larger area of their storefront sign than the 125 sq. ft. maximum as prescribed by the zoning code.

The Ross Dress For Less store at will occupy 17,640 sq. ft. in the former Rite Aid space at Joshua Village Shopping Center. Their lease provides for a 125'-0" frontage. They will be employing around 50 full and part time employees. In accordance with the City's sign code, their sign area is limited to 125 sq. ft. measured as a single rectangle encompassing the wall sign letters. Thus calculated, the proposed 72" hi ROSS and 30" hi DRESS FOR LESS is 258.5 sq. ft. in gross sign area.

Justification:

1. The strict application of the provisions of the Zoning Ordinance would result in practical difficulties or unnecessary hardships consistent with the general purposes and intent of zoning regulations.

In taking the former Rite Aid store, Ross has inherited a rather large storefront. We feel that When a 125 sq. ft. sign is positioned on the large background, it looks disproportionately small and diminishes Ross' presence in the shopping center. Ross Stores, Inc. has signed a long-term lease here. The proposed sign offers them the assurance that they will be seen and recognized.

2. There are special circumstances applicable to the subject property such as size, topography, location or surroundings that do not apply generally to other property in the same zone and vicinity.

If Ross were to comply with the ordinance, the Ross would be 48" high and the Dress For Less would be 20" hi. These sizes are insufficient when viewed from 29 Palms Highway. It's important that they have a sign size that can be read and recognized from such a long distance and that represents their significant size to the public.

The existing Von's sign in the same center is the same height as the proposed Ross letters.

3. Deviation from the zoning provisions is necessary for the preservation and enjoyment of a substantial property right or use generally possessed by other property in the same zone.

As mentioned above, there is already a precedent for a 72" high sign at Joshua Village S/C.

4. The granting of the variance will not be materially detrimental to the public welfare or injurious to the property or improvements in the same zone or vicinity in which the property is located.

The essential character of land use along 29 Palms Highway is retail. The public already associates signage with retail shopping centers, in fact, they depend on it to find the store or facility they are looking for. There is nothing being proposed that contradicts the character of the vicinity.

We believe that the addition of the proposed signage will actually be a material benefit to the public by assisting them in locating the store. *The Signage Sourcebook*, published by the Small Business Administration has documented how properly placed and formatted signs can reduce traffic incidents, finding that small signs distract the driver because they can't find what they're looking for.

5. Allowing a deviation from the Guidelines will not adversely affect any elements of the General Plan.

In fact, the proposed signage actually furthers the goals of the General Plan's Economic Development Element. It's very clear that the proposed signage addresses the stated intentions of this vital element.

Signs are indicative of business activity. The visual impact of this new, dynamic signage will contribute to the retail synergy that the City wants to promote here. The addition of the proposed signs will be in keeping with the tradition of the area while offering a refreshed and contemporary design.

We appreciate the opportunity to present our reasoning behind our request for limited relief from City of Yucca Valley's Zoning Ordinance. We feel that the purposes of the ordinance and General Plan would be advanced by the requested deviations from the requirements and the benefits of such a deviation will substantially outweigh the detriment due to ineffective identification, visibility and the perception of renewed retail vitality.

With this variance request, Ross Stores, Inc. is seeking to remedy the perception the smaller sign would promulgate. It would also signify the relative importance Ross Stores Inc. will play in the local economy.

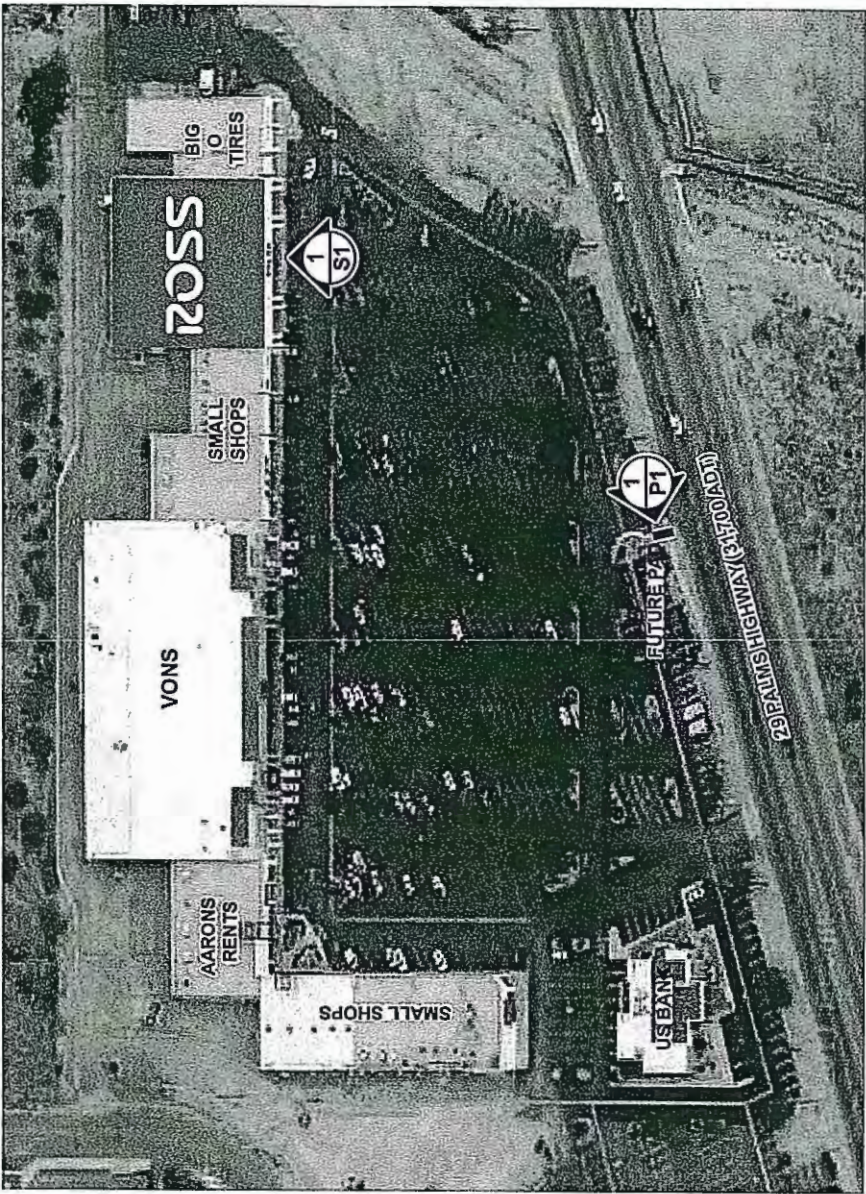
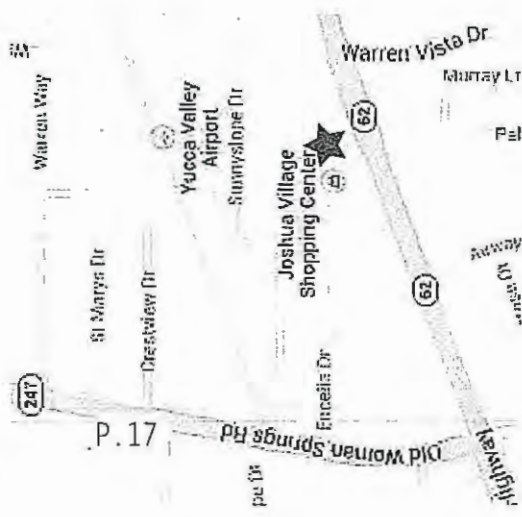
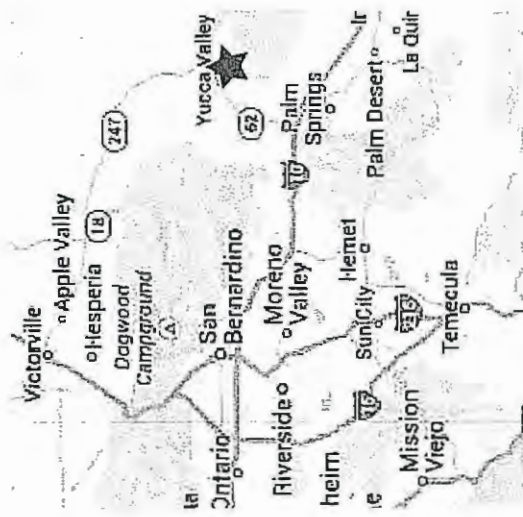

AERIAL VIEW
NOT TO SCALE

SHEET
K

drawn 11/00
rev vic. maps / exhibit J 08/13/14

#1684 YUCCA VALLEY
Joshua Village Shopping Center
NEC 29 Palms Highway & Airway Avenue
Yucca Valley, CA



bill moore & associates
1057 solano ave.
p.o. box 6153
alhambra, ca 91706-0153
510.228-0256 fax 528-8082
www.billmoore.com

VICINITY MAPS
NOT TO SCALE



Notes:

- ROSS CONTRACTOR TO PROVIDE:
- ADEQUATE ACCESS BEHIND LOGO LETTERS FOR INSTALLATION AND MAINTENANCE, PER ARTICLE 600 OF THE N.E.C.
- THREE (3) 20 AMP 120V ISOLATED SIGN CIRCUITS AND JUNCTION BOXES TO AREA BEHIND SIGN LETTERS CONNECTED TO THE ENERGY MANAGEMENT SYSTEM
- AT LEAST 1/2" THICK PLYWOOD BACKING BEHIND ALL E.I.F.S. WALL SYSTEMS FOR SIGN AND BANNER SUPPORT
- SIGN FASCIA TO BE FREE OF JOINTS & REVEALS, AND OF A LIGHT COLOR (MINIMUM 80% L.R.V.) TO PROVIDE HIGH CONTRAST AND VISIBILITY FOR THE SIGN.
- COLOR APPEARANCE MAY BE ALTERED BY PRINTING, SEE APPROVED FINAL CONSTRUCTION DRAWINGS FOR COLOR SPECIFICATIONS.

- (A) 72"H INDIVIDUAL "ROSS" PAN CHANNEL
LOGO LETTERS:
FACES: TUF-GLAS SG 21210-E4 MATTE BLUE
RETURNS: 8"D ALUM. W/ WHITE FINISH
TRIM CAP: 2" WHITE JEWELITE
LETTER BACKS: ALUMINUM
NEON: FOUR-TUBE 15MM EGL E40 BLUE
MOUNTING: 1/4"-20 GALV. THRU BOLTS
PEG OFF: 1/2" SPACERS
- (B) 30"H INDIVIDUAL "DFL" LOGO LETTERS
ALL CALLOUTS SAME AS "ROSS" EXCEPT:
RETURNS: 5"D ALUM. W/ WHITE FINISH
TRIM CAP: 1" WHITE JEWELITE
NEON: THREE-TUBE 15MM EGL E40 BLUE
- (C) 23"H X 46"W X 10"D DOUBLE-FACE
INTERNALLY ILLUMINATED UNDER-CANOPY
SIGN, SEE SHEET UC FOR DETAILS.
- (D) 24"H X 48"W X 1"D SINTRA OVAL
"ROSS" LOGO WALL PLAQUE
TWO (2) REQUIRED AS SHOWN,
SEE SHEET EL FOR DETAILS.

- (1) SIGN FASCIA BY ROSS
CONTRACTOR, SEE NOTES
- (2) TYPICAL ARCHITECTURAL
LIGHTING BY ROSS CONTRACTOR
- (3) TYPICAL ROSS BLUE IDENTITY
BANDS BY ROSS CONTRACTOR
- (4) CLEAR ANODIZED ALUMINUM
STOREFRONT & DOORS BY
ROSS CONTRACTOR
- (5) FROSTED WINDOW FILM BY
ROSS CONTRACTOR
- (6) SET OF FIVE (5) EYE-BOLTS
FOR BANNER ATTACHMENT BY
ROSS CONTRACTOR. TWO (2) SETS
REQUIRED AS SHOWN.
- (7) ADJACENT PARAPET MAY NOT
BE HIGHER THAN ROSS BASE
BUILDING
- (8) SOLAR SHADES BY ROSS
CONTRACTOR. IMAGES MAY VARY
FROM WHAT IS SHOWN, SEE
SHEET WS FOR DETAILS.

P. 18

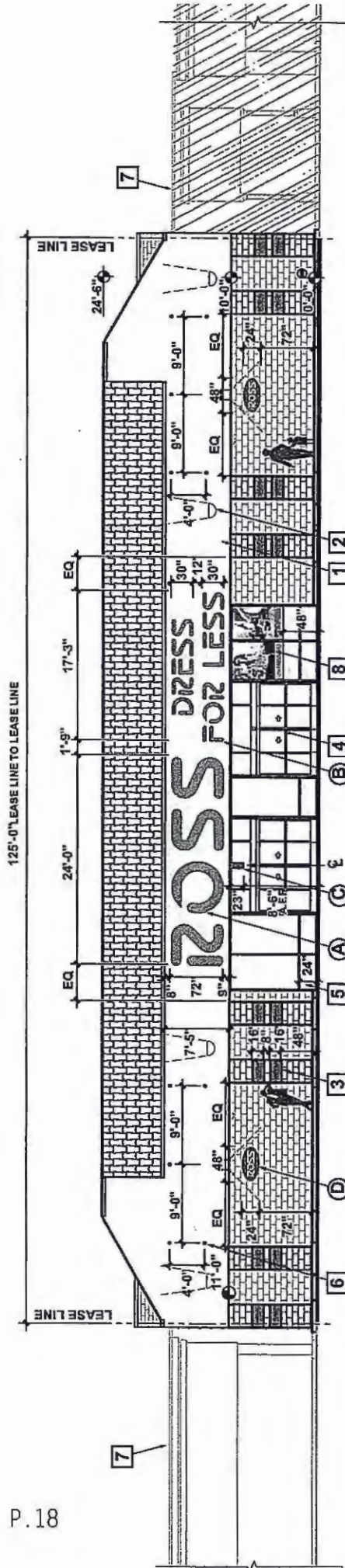

1 STOREFRONT • SOUTH • 29 PALMS HWY. • ELEVATION

OPTIMUM

SCALE: 3/32" = 1'-0"

RB-E

bill moore & associates
1057 adams ave.
p.o. box 6153
albany, ca 94705-0153
510.526.0288 fax 528-5092
www.billmoore.com

USA
MEMBER
INTERNATIONAL
ASSOCIATION
OF
SIGNAGE

ROSS
DRESS FOR LESS

#1684 YUCCA VALLEY
Joshua Village Shopping Center
NEC 29 Palms Highway & Airway Avenue
Yucca Valley, CA

drawn 12/03/12
per AR comment 01/02/13
add dims / exhibil J 08/13/13

SHEET
S1

- (A) TYPICAL WHITE ELECTROBIT ELECTRODE CAP
- (B) TYPICAL MOUNTING HOLE FOR 1/4" THROUGH BOLTS WITH 1/2" THICK NON-CORROSIVE MOUNTING BLOCK SPACER BEHIND LETTER
- (C) TYPICAL SECONDARY FEED HOLE WITH 1/2" THICK NON-CORROSIVE MOUNTING BLOCK SPACER BEHIND LETTER
- (D) TYPICAL NEON UNIT
- (E) ALUMINUM LETTER-BACK
- (F) TYPICAL TRANSFORMER
- (G) TYPICAL APPROVED SPLICE CONNECTOR
- (H) CIRCLE "R": DECAL INSTALLED ON RETURN OF LAST "S"

72" ROSS	30" DRESS/FOR LESS
FEED LOCATION: MIDDLE	FEED LOCATION: BOTTOM/TOP
NEON: 15 MM 4/T EGL E-10 POWDER BLUE	NEON: 15 MM 2/T EGL E-40 POWDER BLUE
TRANSFORMERS: INDOOR LOCATION	TRANSFORMERS: INDOOR LOCATION
AMPS: 14.84	AMPS: 8.67

TOTAL AMPS: 23.51

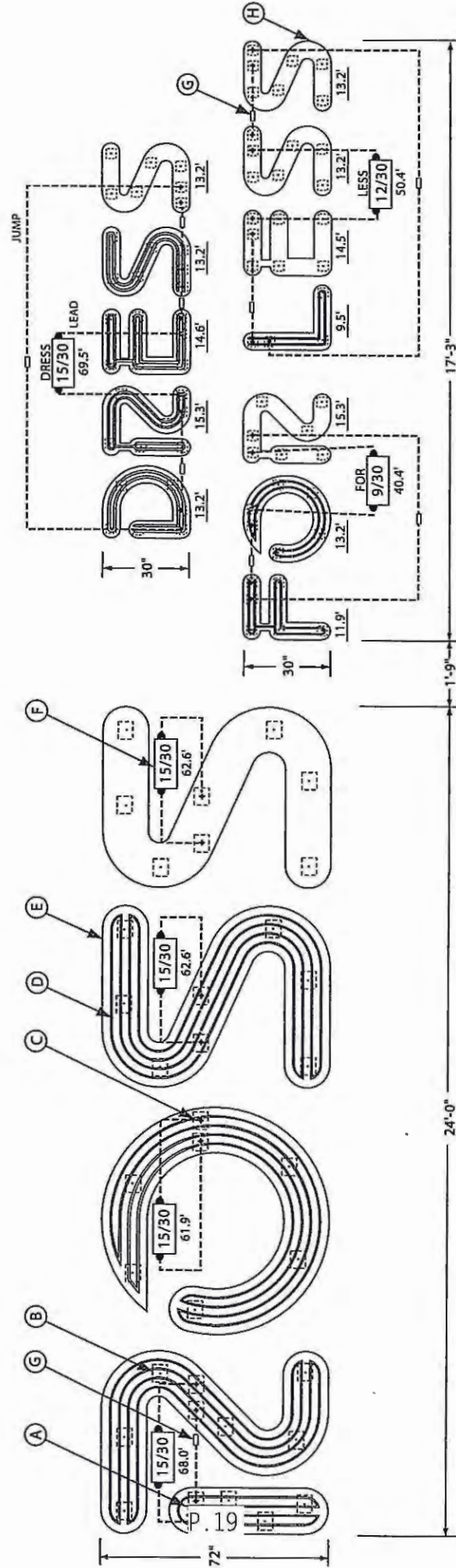

NOTES:
 SEE SHEET S1 FOR SIGN LOCATION AND SHEET SEC1 FOR INSTALL DETAILS.
 SIGN MUST MEET U.L. 2161 AND 2005 NEC SPECIFICATIONS.
 ELECTRICAL CONTRACTOR TO SUPPLY CORRECT NUMBER OF 20 AMP 120 VOLT DEDICATED SIGN CIRCUITS (SEE SIGN ELEVATION FOR QUANTITY).
 TO OPERATE PROPERLY EACH SIGN CIRCUIT MUST BE AN ISOLATED (DEDICATED) 20 AMP 120 VOLT SINGLE PHASE CIRCUIT WITH EQUIPMENT GROUND AND NO COMMON NEUTRAL OR GROUND WIRES. WIRE GAUGE FOR EACH 20 AMP CIRCUIT MUST BE SIZED FOR A 16 AMP LOAD IN ACCORDANCE WITH THE NATIONAL ELECTRIC CODE FOR NO MORE THAN 5% VOLT DROP OVER THE LENGTH OF THE RUN. CIRCUITS MUST BE TERMINATED IN JUNCTION BOXES WITHIN FIVE FEET OF THE SIGN AND CONNECTED TO THE ENERGY MANAGEMENT SYSTEM.

1 NEON & WIRING LAYOUT

N.T.S.

72" ROSS
30" DRESS/FOR LESS



1057 Indiana Ave.
 P.O. Box 6153
 Albany, CA 94708-0153
 510.525-0296 / fax 510-526-6092
 www.billmoore.com

bill moore & associates

ROSS
 DRESS FOR LESS

#1684 YUCCA VALLEY
 Joshua Village Shopping Center
 NEC 29 Palms Highway & Airway Avenue
 Yucca Valley, CA

SHEET
W1

drawn 00/00/00

Notes:

- REFER SHEET S1 FOR UNDER-CANOPY SIGN LOCATION.
- GENERAL CONTRACTOR TO PROVIDE:
- ACCESS ABOVE CEILING FOR SIGN INSTALLATION,
- 120V ELECTRICAL SERVICE
- J-BOX WITHIN FIVE (5) FEET OF SIGN LOCATION (CONNECTED TO ENERGY MANAGEMENT SYSTEM).

1/A TO PROVIDE:

- DOUBLE-FACED ALUMINUM CABINET
 - ESCUTCHEON PLATES AT CEILING
- 2/A INSTALLER TO PROVIDE:**
- WOOD OR STEEL ANGLE CROSS MEMBER (AND WOOD BLOCKING IF NECESSARY); SEE LETTER "B"
 - 2 SCREWS FOR ESCUTCHEON PLATE; PRIME AND PAINT PLATES AND SCREW HEADS TO MATCH CEILING; SEE LETTER "C"
 - 1-1/2" DIA. GALVANIZED STEEL PIPE SUPPORTS (TYP. OF TWO); THREAD ENDS TO SECURE INSIDE CABINET AND ABOVE CEILING. PRIME AND PAINT TO MATCH CEILING. SEE LETTER "D"

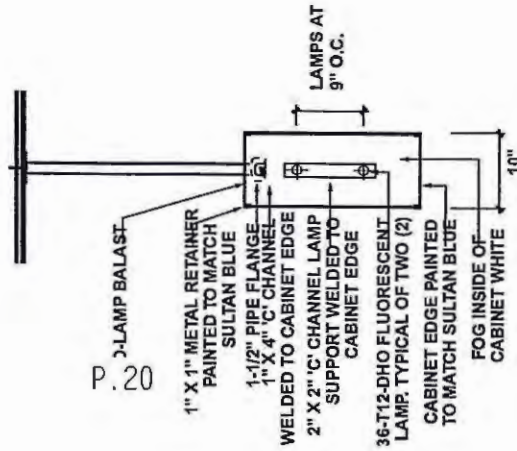

SECTION A-A'

SCALE: 3/4" = 1'-0"

- (A)** WOOD OR STEEL ANGLE CROSS MEMBER (AND WOOD BLOCKING IF NECESSARY) ANCHORED TO CANOPY JOISTS.
- (B)** 2" DIA. HOLE FOR PIPE SUPPORTS; FASTEN PIPES WITH FENDER WASHERS AND LOCK NUTS AS REQUIRED.
- (C)** ESCUTCHEON PLATE AT CEILING; SECURE WITH 2 SCREWS, PRIME AND PAINT PLATES AND SCREW HEADS TO MATCH CEILING
- (D)** 1 1/2" DIA. GALVANIZED STEEL PIPE SUPPORTS (TYP. OF TWO) CUT TO LENGTH FOR FINISH CABINET HEIGHT
- (E)** DISCONNECT SWITCH; INSTALL CABINET SO SWITCH AND U.L. LABEL FACE STORE

- (F)** CABINET: 23" X 46" X 10" DOUBLE-FACED ALUMINUM PRIMED W/ ZINC CHROMATE; CABINET EDGE AND 1" RETAINERS PAINTED TO MATCH SULTAN BLUE (PMS 286).
- (G)** 1/4" DIA. DRAIN HOLE AT BOTTOM OF CABINET (TYP.)
- (H)** WEATHERPROOF SILICONE SEAL AROUND PIPE PENETRATIONS INTO CABINET (TYP.)
- (I)** FACES: 0.177 (3/16") WHITE LEXAN FACE WITH 9 1/4" H "ROSS" COPY AND 3/4" W WHITE IN-LINE REVERSED CUT OF 3M 3630-157 SULTAN BLUE TRANSLUCENT VINYL OVERLAY

Installer to:

- DRILL 2" DIA. HOLES FOR PIPE SUPPORTS; FASTEN PIPES WITH FENDER WASHERS AND LOCK NUTS AS REQUIRED.
- PROVIDE AND CUT TO LENGTH: 1-1/2" DIA. GALVANIZED STEEL PIPE SUPPORTS; THREAD ENDS TO SECURE INSIDE CABINET AND ABOVE CEILING. PRIME AND PAINT TO MATCH CEILING.
- PROVIDE AND USE TWO (2) SCREWS TO SECURE ESCUTCHEON PLATES; PRIME AND PAINT PLATES AND SCREW HEADS TO MATCH CEILING

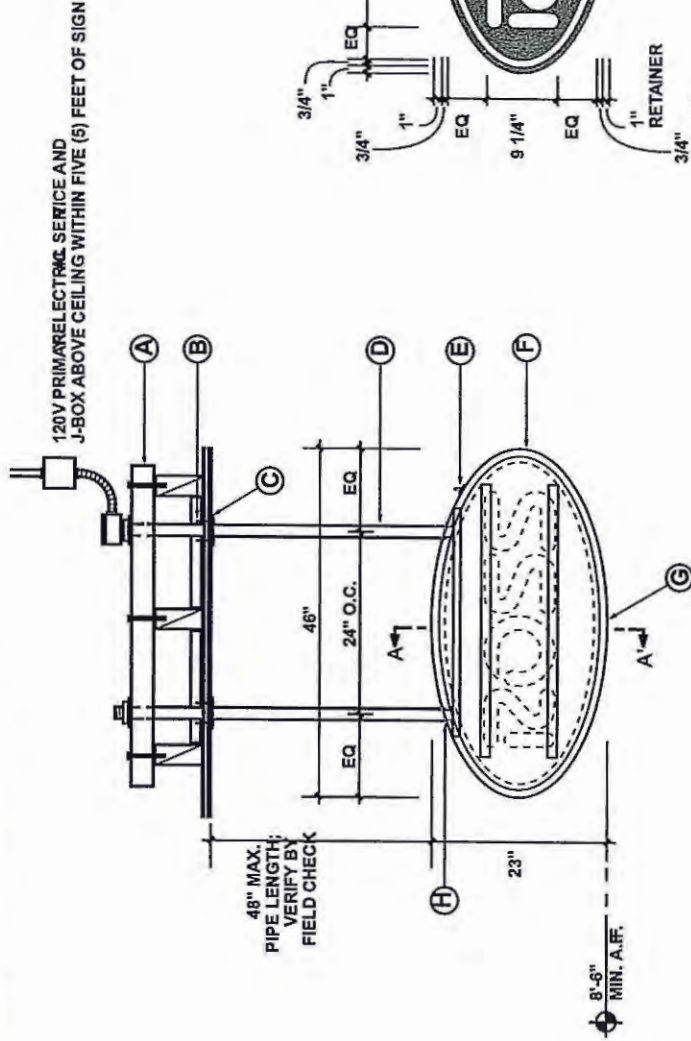

2/D/F UNDER-CANOPY FRAMING ELEVATION

SCALE: 3/4" = 1'-0"

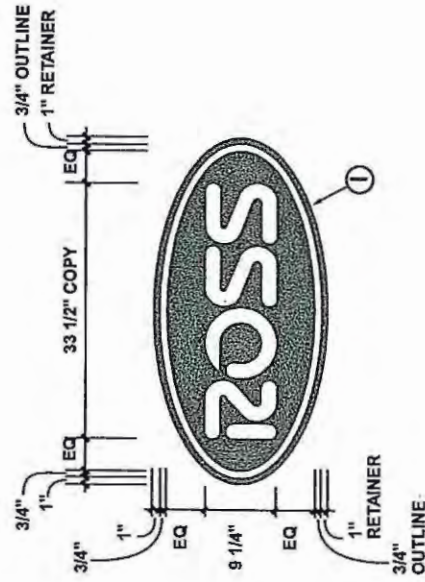

2/I D/F UNDER-CANOPY FACE DETAIL

SCALE: 3/4" = 1'-0"



1057 sabino ave.
p.o. box 9153
albany, ca 94708-0153
510.528-0298 fax 528-0192
www.billmoore.com



#1684 YUCCA VALLEY
Joshua Village Shopping Center
NEC 29 Palms Highway & Airway Avenue
Yucca Valley, CA

drawn exhibit J
08/13/13
08/



Notes:

SEE SHEET S1 FOR PLAQUE LOCATIONS.

GENERAL CONTRACTOR TO PROVIDE:

- VERIFICATION AND PREPARATION OF WALL SURFACE - IF WALL SURFACE IS UNEVEN (EXAMPLE: SPLIT-FACE CMU OR STONE VENEER), GENERAL CONTRACTOR TO KNOCK DOWN ROUGH SURFACE 2" BEYOND EDGE OF PLAQUE SO IT WILL SIT FLUSH AGAINST THE WALL. SEE SECTION A-A BELOW.

BMA TO PROVIDE:

- PLAQUES, HARDWARE AND INSTALLATION PATTERNS TO SIGN INSTALLER
- FULL-SIZED OVAL TEMPLATE TO GENERAL CONTRACTOR TO FACILITATE RESURFACING OF WALLAREA BEHIND PLAQUES. BMA TO VERIFY WALL FINISH BEFORE BENDING PATTERN

SIGN INSTALLER TO PROVIDE:

- GE CONSTRUCTION SC51200 SILICONE SEALANT

- (A) 24"H X 48"W X 1"D SINTRA OVAL "ROSS" LOGO WALL PLAQUE; SEE SHEET S1 FOR LOCATION(S).

- (B) DIGITALLY PRINTED 3M CONTROL TAC GRAPHIC: 9.6"H X 35"W WHITE "ROSS" COPY
 .25" PMS #296C DARK BLUE COPY OUTLINE
 PMS #2945C BLUE BACKGROUND
 .25" PMS #296C DARK BLUE 1ST OUTLINE,
 .625" WHITE 2ND OUTLINE
 .975" PMS #2945C BLUE 3RD OUTLINE

- (C) CLEAR "TEDLAR" GRAFFITI GUARD FILM OVERLAY

- (D) 2" DRESSED AREA (IF NECESSARY)

Installation Instructions:

- DRILL FIVE (5) 5/16" DIA. X 3" DEEP HOLES INTO WALL AS PER PATTERN.
- SCREW 3" X 1/4-20 MACHINE-THREAD END OF GALV. FURNITURE BOLTS INTO EMPTY T-NUTS INTO BACK OF PLAQUE UNTIL THEY CONTACT THE PVC. (DO NOT OVER-TIGHTEN).
- USING GE CONSTRUCTION SC5 1200 SILICONE SEALANT, FILL HOLES IN WALL, COAT SCREW-THREAD ENDS OF FURNITURE BOLTS AND APPLY HEAVY BEAD TO BACK OF PLAQUE
- MOUNT PLAQUE ONTO WALL BY PUSHING BOLTS INTO HOLES UNTIL PLAQUE IS FLUSH AGAINST WALL SURFACE.

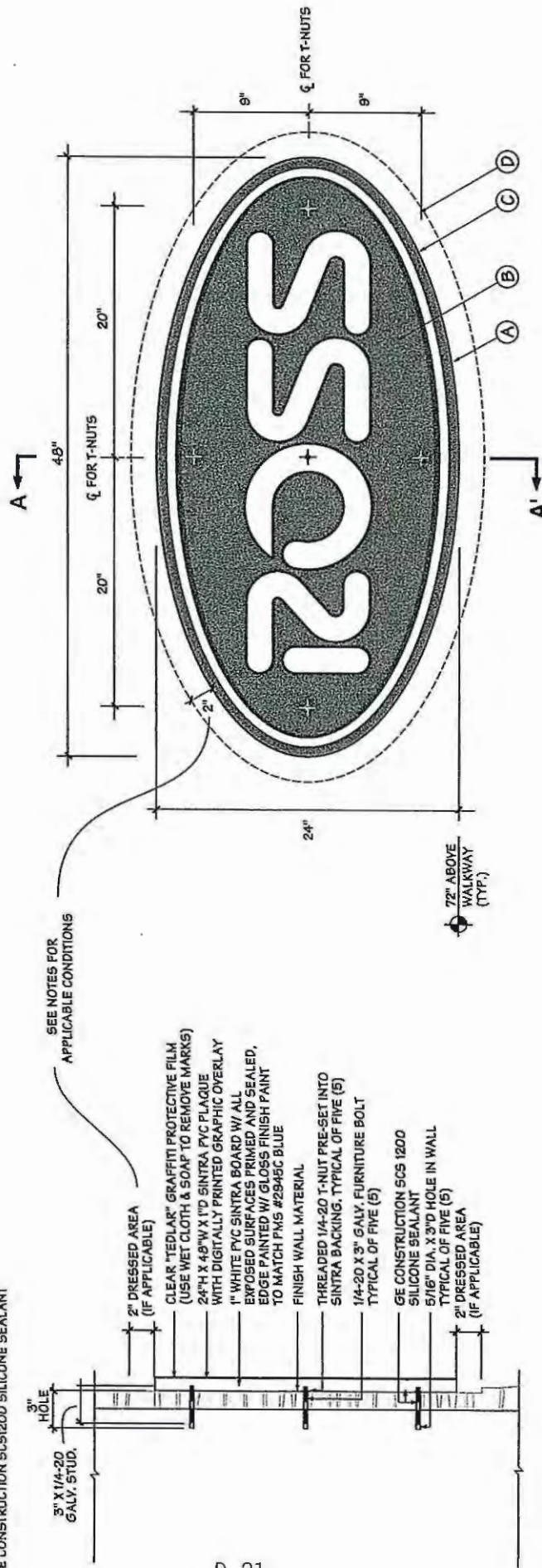

② SECTION A-A' AT MOUNT

SCALE: 1-1/2" = 1'-0"

① OVAL ENTRANCE LOGO PLAQUE ELEVATION

SCALE: 1-1/2" = 1'-0"



1057 solano ave.
 p.o. box 6133
 daly city, ca 94026-0133
 510/926-0298 fax 526-6092
 www.billmoore.com



#1684 YUCCA VALLEY
 Joshua Village Shopping Center
 NEC 29 Palms Highway & Airway Avenue
 Yucca Valley, CA

drawn
 Exhibit J

08/13/13
 08/13/13

SHEET
EL



PLANNING COMMISSION STAFF REPORT

To: Chairman & Planning Commission
From: Shane Stueckle, Deputy Town Manager
Date: April 03, 2014
For Commission Meeting: April 08, 2014

Subject: Development Code Amendment, DCA-07-13
Draft Development Code Article 3
General Development Standards

Prior Commission Review: The Planning Commission received a presentation on Article 3 at its meetings of April 23, 2013, May 07, 2013, May 14, 2013 and March 11, 2014.

Recommendation: That the Planning Commission:

- A. Finds that the project is exempt from CEQA in accordance with Section 15061 (b)(3) of the California Environmental Quality Act. The proposed amendment to revise the Town’s Permitting Procedures regulations has no potential to impact the environment. The proposed amendment does not alter the existing requirements that specific development projects must comply with the provisions of the California Environmental Quality Act. Development Code Amendment, DCA 06-03 meets the exemption criteria which states “that if an activity is covered by the general rule that CEQA applies only to projects which have the potential for causing a significant effect on the environment and where it can be seen with certainty that there is no possibility that the activity in question may have a significant effect on the environment, the activity is not subject to CEQA”
- B. Recommends that the Town Council adopts the Ordinance and repeals Municipal Code Sections 41.151 thru 41.1569 and Development Code Sections 84.0701 thru 84.0740, 87.0201 thru 87.220, 87.0401 thru 87.0405, 87.0505, 87.0601 thru 87.0645, 87.0901 thru 87.0940, 88.0805 thru 88.0810, 810.0101 thru 810.0135, 810.0201 thru 810.0275, and 9.75.010 thru 9.75.130,

Executive Summary: As part of the Development Code Update project, the Planning Commission reviewed Article 3 at its meetings of April 23, 2013, May 07, 2013, May 14, 2013 and March 11, 2014.

<input type="checkbox"/> Department Report	<input checked="" type="checkbox"/> Ordinance Action	<input type="checkbox"/> Resolution Action	<input checked="" type="checkbox"/> Public Hearing
<input type="checkbox"/> Consent	<input type="checkbox"/> Minute Action	<input type="checkbox"/> Receive and File	<input type="checkbox"/> Study Session

Article 3 provides standards for Dedications and Infrastructure Improvements, Landscaping, Parking, Performance Standards, Property Maintenance, Sign Regulations, Soil Erosion and Dust Control, Temporary Special Events, Temporary Uses, Surface Mining and Land Reclamation, Trip Reduction, Accessory Energy Systems, Wireless Communication Facilities, and Cemeteries

Order of Procedure:

- Request Staff Report
- Open the Public Hearing,
- Request Public Comment
- Close the Public Hearing
- Council Discussion/Questions of Staff
- Motion/Second
- Discussion on Motion
- Call the Question (Voice Vote)

Discussion: Article 3, General Development Standards, provides standards for the development of property

Seventeen Chapters are established within Article 3, and those Chapters are structured in the following manner:

- | | |
|--------------|---|
| Chapter 9.30 | Dedications and Infrastructure Improvements |
| Chapter 9.31 | General Development Standards |
| Chapter 9.32 | Landscaping and Water Conservation |
| Chapter 9.33 | Parking and Loading Regulations |
| Chapter 9.34 | Performance Standards |
| Chapter 9.35 | Property Maintenance Standards |
| Chapter 9.36 | Sign Regulations |
| Chapter 9.37 | Soil Erosion and Dust Control |
| Chapter 9.38 | Temporary Special Events |
| Chapter 9.39 | Temporary Uses and Structures |
| Chapter 9.40 | Surface Mining and Land Reclamation |
| Chapter 9.41 | Trip Reduction Requirements |
| Chapter 9.42 | Accessory Solar Energy Systems |
| Chapter 9.43 | Accessory Wind Energy Systems |
| Chapter 9.44 | Wireless Communications Facilities |
| Chapter 9.45 | Cemeteries |
| Chapter 9.46 | Renewable Energy Generation Facilities |

Chapter 9.30 Dedications and Infrastructure Improvements

Chapter 9.30 regulates and controls the dedications and the installation of infrastructure improvements such as streets, traffic signals, utilities, or flood control measures

Chapter 9.31 General Development Standards

Chapter 9.31 establishes standards for the clear sight triangle and height regulations

Chapter 9.32 Landscaping and Water Conservation

Chapter 9.32 establishes minimum landscape standards for the construction of landscapes over 2500 square feet within new commercial, industrial or residential projects, within homeowner installed landscaping over 5000 square feet and within cemeteries.

Chapter 9.33 Parking and Loading Regulations

Chapter 9.33 establishes regulations for the required parking and loading facilities, for parking lot layout for the design of parking lots, commercial truck parking requirements and landscaping requirements within parking lots.

Chapter 9.34 Performance Standards

Chapter 9.34 establishes performance standards to guard against the use of any property that would create hazardous conditions in regards to Air Quality, Electrical Disturbances, Fire Hazards, Heat, Noise, Vibration or Waste Disposal.

Chapter 9.35 Property Maintenance Standards

Chapter 9.35 provides property maintenance standards for residential property in regards to structure maintenance, fencing, visible storage, litter and refuse, parking areas and landscaping and vegetation.

Chapter 9.36 Sign Regulations

Chapter 9.36 establishes regulation for the installation and maintenance of commercial and industrial permanent signs, temporary commercial signs, residential signs, public and institutional facility directional signs and real estate signs in regards to size, number, design and location.

Chapter 9.37 Soil Erosion and Dust Control

Chapter 9.37 establishes standards and process for regulating development that disturbs the surface of the land.

Chapter 9.38 Temporary Special Events

Chapter 9.38 provides development standards for the temporary special events such as carnivals, certified farmers markets, car shows or seasonal holiday facilities.

Chapter 9.39 Temporary Uses and Structures

Chapter 9.39 provides standards for temporary structures or uses such as batch plants, temporary residential quarters, temporary construction office, temporary model homes, or temporary work trailers.

Chapter 9.40 Surface Mining and Land Reclamation

Chapter 9.40 provides regulation for the extraction of minerals and the reclamation of mined lands.

Chapter 9.41 Trip Reduction Requirements

Chapter 9.41 provides regulations for the reduction of vehicle trips to reduce air congestion and pollutants and to improve air quality.

Chapter 9.42 Accessory Solar Energy Systems

Chapter 9.42 establishes development standards in regards to height, setbacks and visibility for the installation of solar energy for onsite consumption.

Chapter 9.43 Accessory Wind Energy Systems

Chapter 9.43 establishes development standards such as number allowed, height, setbacks, lighting, noise, and location for the installation of wind energy systems for onsite consumption

Chapter 9.44 Wireless Communications Facilities

Chapter 9.44 provides development standards for the installation of wireless communication facilities in regards to special design areas, zoning districts, review process, visual impact and screening and abandonment of facilities.

Chapter 9.45 Cemeteries

Chapter 9.45 provides standards for the establishment or expansion of a cemetery.

Chapter 9.46 Renewable Energy Generation Facilities

Chapter 9.46 prohibits the development of renewable energy generation facilities within any land use district.

Alternatives: The Planning Commission may elect to make recommended changes to the Article.

Fiscal impact: This Ordinance is included in the Town's contract for the Development Code Update project. No additional costs are incurred beyond existing contract services.

Attachments:

Article 3, General Design Standards

Planning Commission minutes from April 23, 2013, May 07, 2013, May 14, 2013 and draft minutes from March 11, 2014

**TOWN OF YUCCA VALLEY
PLANNING COMMISSION MEETING MINUTES
APRIL 23, 2013**

Chair Humphreville called the regular meeting of the Yucca Valley Planning Commission to order at 6:00 p.m.

Commissioners Present: Bridenstine, Drozd, Humphreville, and Whitten.

The Pledge of Allegiance was led by Chair Humphreville.

APPROVAL OF AGENDA

Commissioner Whitten moved to approve the agenda for the Planning Commission meeting of April 23, 2013. Commissioner Bridenstine seconded. Motion carried 4-0-1 on a voice vote.

PUBLIC COMMENTS

None

DEPARTMENT REPORT:

1. SELECTION OF PLANNING COMMISSION CHAIRMAN AND VICE-CHAIRMAN

Chair Humphreville opened nominations for the position of Planning Commission chairman. Commissioner Bridenstine nominated Chair Humphreville for another term. Commissioner Whitten nominated Bridenstine. Bridenstine declined the nomination. Whitten nominated Commissioner Drozd. Drozd declined the nomination. Drozd seconded the nomination for Humphreville. Motion carried, 4-0-1.

Chair Humphreville opened nominations for the position of Planning Commission vice-chairman. Commissioner Whitten nominated Commissioner Bridenstine. Commissioner Drozd seconded. Motion carried 4-0-1

2. DRAFT DEVELOPMENT CODE

Deputy Town Manager Stueckle presented the item regarding Article 3 of the Draft Development Code.

Planning Commissioners provided feedback on the draft document. Commissioner Bridenstine questioned the process of proof of legal and physical access. Stueckle responded that this language was provided because of the unique topography in our area.

Commissioner Bridenstine continued by asking about existing wells in the service area described on page 3-3, paragraph 2 (b) Stueckle suggested adding a paragraph to address this. Bridenstine commented on necessary street paving in the 2.5 acres and less section, and is concerned that some residents with 2.5 acre parcels might want to live on a dirt road. Bridenstine would like it to read 1 acre or less instead of at 2.5 acres or less.

Commissioner Whitten commented the language for street improvements and terminology applicable to subdivisions is confusing.

Chair Humphreville spoke in regards to page 3-2 (a) offered that two-wheeled drive is sufficient and questioned if the language needed to be that specific.

Deputy Town Manager Stueckle introduced section 3-6 and invited commissioner feedback. Commissioner Whitten inquired about building permit requirements in reference to entries included in table 3-2. Commissioner Drozd questioned height limit of 25 feet or higher. Commissioners gave consensus of offering a percentage of over standard height instead of specific footage. Commissioner Bridenstine commented on the frequent violations of movable signs within the clear sight triangle.

Deputy Town Manager Stueckle continued to present draft page 3-10 and explained the new features including reference to front and street-side landscaping and setbacks. Stueckle fielded several Commissioner inquiries regarding native plants, landscape plans, replanting, and water usage included in this section. Chair Humphreville suggested that language be included about fill yardage. Commissioner Bridenstine suggested adding language to page 3-16, item 10 to define high-maintenance landscaping.

Deputy Town Manager Stueckle presented the next section, 3-26 regarding parking regulations. Commissioner Drozd questioned the permitting process of allowable carports. Commissioner Bridenstine commented on the need of a formula to calculate required parking spaces for a given project. Bridenstine also concerned about the continued use of angled parking in Yucca Valley as addressed on page 3-34. Chair Humphreville suggested separating the parking requirements for convalescent hospitals, and retirement homes and also questioned the mixed use properties, such as golf courses with a restaurant. Truck parking in residential areas was briefly discussed. Commissioner Bridenstine suggested correcting page formatting to keep tables all on one page.

Deputy Town Manager Stueckle continued by presenting the next section regarding performance standards. Commissioner Drozd questioned heat emissions on page 3-47 and how light trespasses from yard lighting are measured. Stueckle responded that lighting standards are included in the building and construction section. Drozd also inquired if

overnight RV parking in Wal Mart's parking lot is enforceable.

Commissioner Bridenstine questioned noise standards and how the listed levels were determined. Commissioner Whitten questioned language in 3-51 regarding faulty equipment, hazardous materials and suggested the addition of asbestos surveys.

Continuing on with section 3-52, Stueckle presented an update regarding property maintenance standards and typical uses. Chair Humphreville commented on 3-55 (b) and maintenance issues he has experienced. Discussion continued on operable vehicles per property. Humphreville asked about the time limits of inoperable vehicles on properties, such as those under repair. Commissioner Bridenstine suggested placing a limit on the number of vehicles allowed to continually park on a property. Commissioner Whitten offered addressing non-op vehicles by being screened and out of view and also questioned page 3-53 as to what level of needed maintenance triggers action.

Chair Humphreville suggested to continue the section on sign regulations to a future meeting to allow specific community outreach for public input. Commissioner consensus was made.

Deputy Town Manager Stueckle explained the process for approval for wireless communication facilities. Chair Humphreville suggested keeping wireless facilities to commercial property to eliminate a CUP.

Deputy Town Manager Stueckle presented the background regarding the section on trip reduction in the Draft Development Code. Commissioner Whitten inquired about the use of the Yucca Valley Park and Ride. Commissioner Bridenstine commented that this section is not practical with the local topography and suggested golf cart or electric vehicle use be added. Chair Humphreville suggested that use of golf carts, especially in the country club area should be allowed on residential streets.

No motion was made for this item.

STAFF REPORTS AND COMMENTS

Deputy Town Manager Stueckle gave an update on Town Council meetings may conflict with the Planning Commission's regular meeting schedule in May, 2013.

COMMISSIONER REPORTS AND REQUESTS

Commissioner Bridenstine thanked fellow commissioners and staff members for a productive meeting.

Commissioner Drozd thanked staff for their guidance.

Commissioner Whitten thanked the media for staying through the long meeting.

Chair Humphreville expressed appreciation for staff's work.

ANNOUNCEMENTS

The next regular meeting of the Yucca Valley Planning Commission will be held on Tuesday, May 14, 2013 at 6:00 p.m. in the Yucca Room of the Yucca Valley Community Center.

ADJOURNMENT

There being no further business, the meeting was adjourned at 8:25 p.m.

Respectfully submitted,

Lesley Copeland, CMC
Deputy Town Clerk

**TOWN OF YUCCA VALLEY
PLANNING COMMISSION MEETING MINUTES
MAY 7, 2013**

Chair Humphreville called the regular meeting of the Yucca Valley Planning Commission to order at 6:00 p.m.

Deputy Town Clerk presented the Oath of Office to M.F. Warren Lavender.

Commissioners Present: Bridenstine, Drozd, Lavender, Whitten, and Humphreville.

The Pledge of Allegiance was led by Chair Humphreville.

APPROVAL OF AGENDA

Commissioner Whitten moved to change the order of the agenda, to move the department report after the public hearing. Motion died for a lack of second.

Bridenstine moved to approve the agenda. Chair Humphreville seconded. Motion carried 4-0-1 on a voice vote.

PUBLIC COMMENTS

None

DEPARTMENT REPORT:

1. DRAFT DEVELOPMENT CODE

Deputy Town Manager Shane Stueckle presented a staff report and PowerPoint presentation. At the request of the Planning Commission at a prior meeting, Article 3 of the Draft Development Code relating to sign regulations is being brought in front of the commission for separate review. Existing general allowances in the Sign Ordinance were explained. Stueckle explained areas for specific review including sign height, design merits, square footage for free standing signs and wall signage.

Deputy Town Manager Stueckle continued to explain that amortization schedules are commonly used to address non-conforming signs. Proposed modifications are amortized based on fair market value from the Date of Notice and a time schedule for compliance. Stueckle explained that temporary signs and how to regulate them, such as banners, flags, pennants, hulas, political, and temporary subdivision signs is also an area needing attention.

Jennifer Collins, Yucca Valley, introduced others present at the meeting and spoke of input received through the Yucca Valley Chamber of Commerce office. Collins explained that these suggestions were forwarded to the Planning Commission for consideration.

Fritz Koenig, Yucca Valley, presented a document to the Planning Commission and commented that the purpose of the Sign Ordinance does not include any reference to improving the economy. Mr. Koenig suggested creating a sign ordinance that is in relation to local resources, not compared to other larger cities.

Tom Huls, Yucca Valley, explained that his business, Big O Tires sets back off the highway, and the recent relaxation of the sign code has helped his business tremendously. The use of temporary signage when used responsibly by business owners is very helpful. The Sign Code itself was created for the big business entities, but not for the small businesses we have in Yucca Valley.

Commissioner Drozd asked if the sign square footage is measured on letter size or background. Engineering Technician, Diane Olsen responded that the measurement would be taken by squaring off the total area.

Commissioner Bridenstine agreed that signage is very important and should be easy to see and of appropriate size for traffic view. Signage should be in good taste and well kept, but not to be as harmonious as the current code limits. The community expects signage in a commercial district. Signage, including temporary signage should not be blocking line of sight for safety reasons. Agrees with Mr. Koenig's comment about including the purpose of regulating signage is to promote business.

Commissioner Whitten thanked those in attendance for coming out this evening and questioned how many suggestions provided by the Chamber of Commerce group was included in the draft document. Also agreeing with Koenig's statement recommending a purpose of a sign ordinance should be included. Commissioner Whitten commented on his observation of the current signage throughout the community. Need to give the small businesses a chance to compete with the larger businesses and spoke of the benefit of monument signage.

Commissioner Whitten continued to discuss temporary signage including political signage. Twirler type signs provide employment for the youth of the community and help businesses that set back away from the road. Whitten also spoke on the limits of mural type signage on the side of buildings.

Commissioner Lavender spoke in favor of taking a relaxed attitude toward sign regulations.

Chair Humphreville asked Huls, what specific temporary signage he used to promote his business and asked about typical amortization schedule limits. Stueckle responded that 20 years is usually the maximum, usually based on value. Olsen also explained the inclusion of the Design Merits Program and the Landmark Signage Program to take into account historical signage. Humphreville stated he would like to see the signs stay smaller, yet

appealing and more effective; would like to see the consultant's recommendation. Political signage should have limits on size and frequency.

Commissioner Bridenstine would like to see an amortization schedule included in the new sign regulations, including an incentive such as reduced fees to encourage sign owners to bring into compliance. Signs should not be higher than the roof lines.

Commissioner Drozd agreed with including an amortization schedule as a fair and consistent avenue to bring signs into compliance and also suggested using type of business ownership instead of square footage to regulate signage to help with the smaller, mom and pop type stores. Stueckle responded that one way to possibly address this is to regulate signage by the sign size itself, not by allowing signage size to be based on property or building size.

Commissioner Lavender questioned the use of frontage feet as a tool for regulation. The Ideal Mall property was given as an example of an area where a monument type sign addressing all occupants of that property consistently.

Deputy Town Manager Stueckle presented information on the draft development code section 3-19 regarding commercial solar and wind energy. With tax incentives in effect, property used for energy production limits the amount of property tax collected. Consensus was made among all commissioners present to not allow commercial solar or wind energy within Town limits.

Commissioner Lavender questioned the use of residential solar energy and the possibility of including provisions for home solar use. Stueckle responded that section 3-23, accessory energy systems provides guidelines for residential alternate energy use. Commission discussion continued, questioning the use of roof mount vs. pole mount systems, the need for roof designs of both commercial and residential buildings to accommodate solar panels, and the use of renewable energy parking lot and accessory lights. The use of solar energy when possible was encouraged by the commissioners.

Deputy Town Manager Stueckle recommended that this item be continued to the May 14, 2013 Planning Commission meeting for further discussion.

PUBLIC HEARINGS:

2. DEVELOPMENT CODE AMENDMENT, DCA 01-13, REASONABLE ACCOMODATIONS

Proposed amendment to Title 8, Yucca Valley Development Code adding Article 9, Section 83.0309 et al, Reasonable Accommodations, to provide reasonable accommodations in the Town's zoning and land use regulations, policies and procedures when needed to ensure equal access to housing and facilitate the development of housing for individuals with disabilities.

Deputy Town Manager Stueckle presented the staff report explaining that it is necessary to update the ordinance to bring into compliance, giving reasonable accommodations for those with disabilities. New construction will usually not be affected by these changes; however older, existing buildings may see the effects of this state mandate.

Chair Humphreville opened public comment. With no one wishing to speak on the item, the public comment period was closed.

Commissioner Bridenstine asked if fees would be charged for the variance process. Stueckle responded, that fees will not be charged as the intent of state law.

Commissioner Whitten moved that the Planning Commission find that the proposed ordinance is exempt from CEQA under Section 15061 (b) (3) and recommends that the Town Council adopt the ordinance. Bridenstine seconded. Motion carried 4-0-1 on a voice vote.

3. DEVELOPMENT CODE AMENDMENT, DCA 03-13, EMERGENCY TRANSITIONAL HOUSING AND SINGLE ROOM OCCUPANCY

Proposed amendment to Title 8, Yucca Valley Development Code to amend Section 84.0370 to allow emergency transitional housing subject to a Special Use Permit and single room occupancy units subject to a Conditional Use permit in the Industrial land use district.

Deputy Town Manager Stueckle presented the staff report explaining the provisions in the current general plan housing element regarding emergency transitional housing. The ordinance presented here, establishes reasonable standards providing elements to Town staff for granting approval of homeless shelter facilities within the industrial land-use district. Stueckle gave examples of these reasonable standards and explained that the shelters are for use by those who are homeless and need emergency shelter, and not for long-term or used as an emergency shelter due to a local disaster.

Deputy Town Manager Stueckle explained the second component of the state mandate requiring this ordinance mandates the Town to provide transitional housing and supportive housing. The Town is also required to develop Single Room Occupancy capacity with at least one land use district. All projects are subjected to the Conditional Use Permit process.

Chair Humphreville opened public comment.

Fritz Koenig, Yucca Valley voiced concern that the locations of such shelters, have reasonable access to bus stops, laundry facilities and spoke in favor of building clusters of high-density to fulfill these requirements.

With no others wishing to speak, Humphreville closed public comment.

Deputy Town Manager Stueckle again explained that the item before the commission was for emergency homeless sheltering and does not address sheltering for those affected by natural disaster. Industrial areas are scattered around different areas within the Town limits, to give opportunity for sheltering units.

Commissioner Bridenstine asked for clarification of the term transitional and supportive housing.

Commissioner Whitten asked if there were current numbers representing the homeless population and suggested alternative wording regarding the use of illegal drugs and alcohol. Whitten also asked if trailer parks could be used as supporting or transitional housing as he has seen in other communities.

Commissioner Lavender asked if the state is providing any monetary provisions for financing these mandates. Stueckle explained the mandate is for provisions, but not for the actual construction of actual units. Other funding options may be available on a project by project basis.

Commissioner Whitten moved that the Planning Commission recommends that the Town Council finds the proposed ordinance exempt from CEQA under Section 15061 (b) (3), and adopts the ordinance. Commissioner Bridenstine seconded. Motion carried 4-0-1 on a voice vote.

4. DEVELOPMENT CODE AMENDMENT, DCA 04-13, SECOND DWELLING UNITS

Proposed amendment to Title 8, Yucca Valley Development Code amending Section 84.0305 (b), 84.0320(b), 84.0325(b) and 84.0510, pertaining to second dwelling

units.

Deputy Town Manager Stueckle presented the staff report regarding the state mandate requirement the amendment of the Development Code pertaining to second living dwellings in designated zones. State law requires cities and counties to enact second unit regulations that support and facilitate the development of second units as a means of encouraging and supporting affordable housing, on all residentially designated parcels. Existing Town regulations must be amended to encourage and support second units on all residential lots.

Deputy Town Manager Stueckle continued by explaining ordinance provisions including, that the owner must live in one of the two units and cannot be owned by an investor. Also there is a need to eliminate the language about caretaker housing.

Chair Humphreville opened public comment.

Fritz Koenig, Yucca Valley, commented about enforcement of second units. The minimum standard presented at 725 square feet is not necessary and suggested the commissioners to look at architectural drawings for small living spaces. Less than 725 square feet is sufficient for many people.

With no others wishing to speak, Humphreville closed public comment.

Commissioner Whitten agreed with Mr. Koenig regarding the minimum standard of 725 square feet, being quite large for a second unit minimum and suggested using a percentage instead. Stueckle suggested that all sections work with each other including ancillary structures. Whitten expressed the need for further discussion on this particular language.

Chair Humphreville suggested that provisions for enforcement may need to be included such as property title disclosure.

Commissioner Whitten moved to approve that the Planning Commission recommends that the Town Council finds the proposed ordinance exempt from CEQA under Section 15061 (b) (3), and adopts the ordinance, without the inclusion of 84.0510 (a) due to caretaker language. Commissioner Drozd seconded. Motion carried 4-0-1 on a voice vote.

CONSENT AGENDA

STAFF REPORTS AND COMMENTS

Deputy Town Manager Stueckle explained that a public hearing was scheduled on May 14, 2013 regarding Affordable Housing, Article 3 of the Draft Development Code.

There will be an Public Hearing for an appeal of director approval of an HOP permit regarding firearm sales.

Super Wal Mart opening day was moved a month further out to July 2013.

Warren Vista Center Phase 2 under construction.

COMMISSIONER REPORTS AND REQUESTS

Commissioner Bridenstine thanked staff for their hard work and thanked the public for the comments.

Commissioner Drozd gave kudos to staff and appreciated the public comment heard tonight.

Commissioner Lavender thanked staff for explaining the items.

Commissioner Whitten thanked the public for their input and thanked staff for their work on these items. Whitten questioned the allowance of parking in the front yard due to septic issues and compaction problems.

Chair Humphreville welcomed Mr. Lavender to the Planning Commission

ANNOUNCEMENTS

The next regular meeting of the Yucca Valley Planning Commission will be held on Tuesday, May 14, 2013 at 6:00 p.m. in the Yucca Room of the Yucca Valley Community Center.

ADJOURNMENT

There being no further business, the meeting was adjourned at 8:11 p.m.

Respectfully submitted,

Lesley Copeland, CMC
Deputy Town Clerk

**TOWN OF YUCCA VALLEY
PLANNING COMMISSION MEETING MINUTES
MAY 14, 2013**

Chair Humphreville called the regular meeting of the Yucca Valley Planning Commission to order at 6:00 p.m. All Commissioners were present.

The Pledge of Allegiance was led by Chair Humphreville.

APPROVAL OF AGENDA

Vice Chair Bridenstine moved to approve the agenda. Commissioner Whitten seconded. Motion carried 5-0-0-0 on a voice vote.

PUBLIC COMMENTS

None

PUBLIC HEARING

1. DEVELOPMENT CODE AMENDMENT, DCA 02-13 DENSITY BONUS

Deputy Town Manager Shane Stueckle presented a staff report and PowerPoint presentation explaining the State requires cities to establish density bonus and development incentive standards and regulation for projects of five (5) units or more which provide affordable housing units within the development. The Town is required to update its regulations for consistency with state law. Stueckle presented a summary of Senate Bill 1818.

The proposed Development Code amendment is to add Chapter 11, Division 7, Title 8 of the Town of Yucca Valley Municipal Code to establish density bonuses for affordable housing and other similar projects consistent with State law requirements.

Chair Humphreville opened public comment. With no one wishing to speak, the public comment period was closed.

Commissioner Whitten inquired about the inclusion of very low income standards according to the California Health & Safety Code into the density bonus.

Vice Chair Bridenstine commented on the income thresholds and suggested including how the thresholds are calculated.

Commissioner Whitten moved to find that the proposed ordinance is exempt from CEQA under Section 15061 (b) (3) and recommends that the Town Council adopt the Ordinance. Commissioner Drozd seconded. Motion carried 5-0-0-0 on a voice vote.

DEPARTMENT REPORT

2. DRAFT DEVELOPMENT CODE

Deputy Town Manager presented the staff report on Draft Development Code, Article 3 as an ongoing review of the Development Code Update project.

Chair Humphreville opened public comment. With no one wishing to speak, the public comment period was closed.

Commissioner Drozd spoke in favor of solar use in residential areas, yet voiced concern of the possible noise resulting from wind turbine use.

Chair Humphreville questioned if there were results from a recent study from other municipalities regarding lot sizes and approved alternative energy sources.

Deputy Town Manager Stueckle replied that staff would bring back information on noise levels emitted from the various types of wind turbines.

Commissioner Whitten commented on issues seen in other communities regarding the alternative energy systems, where easements were established to reduce the blockage of sun or wind by neighboring structures and suggested taking this option into consideration.

Vice Chair Bridenstine commented on limiting turbine tower heights and believes that prior Commission discussion stated 25-30 feet; views should not be obstructed.

Chair Humphreville questioned if any Title 24 regulations would hinder the use of alternative energy.

Commissioner Drozd expressed concern for regulating solar and wind technology with local contractors. Deputy Town Manager Stueckle replied that currently, as long as the contractor is in compliance with California Building Code, the permits are approved.

Commissioner Whitten asked about the regulatory process with self-install projects. Self-install should be included. Public information would assist in educating the public on the misconceptions of alternative energy.

Commissioner Lavender commented on CEC standards and wind turbine noise levels.

Deputy Town Manager Stueckle continued to explain proposed changes on pages within Article 3.

Chair Humphreville opened public comment on this section. With no one wishing to speak, the public comment period was closed.

Commissioner Whitten questioned page 3-92, paragraph 1 on how occupancy was authorized and does not believe that authorization, time limits or occupancy type is not explained very well in the document.

Planning Technician Diane Olsen explained the current approval process for a Special Event Permit. Discussion continued on the need for community events and a user-friendly process to encourage events in the area.

No action occurred on this item.

CONSENT AGENDA

Vice Chair Bridenstine moved to approve the minutes of the April 9, 2013 Planning Commission Meeting minutes. Commissioner Whitten seconded. Motion carried on a 5-0-0 voice vote.

STAFF REPORTS AND COMMENTS

Deputy Town Manager Stueckle announced that an HOP hearing is scheduled for the June 11, 2013 Planning Commission meeting and gave a brief update on local commercial construction projects.

COMMISSIONER REPORTS AND REQUESTS

Commissioner Drozd thanked staff.

Commissioner Lavender commented on Yucca Valley's new west-entrance sign.

Commissioner Whitten thanked staff for their work and questioned the condition of the grass at Essig Park.

Vice Chair Bridenstine also thanked staff for their work on the Draft Development Code.

Chair Humphreville commented he has been approached by local contractors looking for information on the new Affordable Senior Housing Project.

ANNOUNCEMENTS

The next regular meeting of the Yucca Valley Planning Commission will be held on Tuesday, June 11, 2013 at 6:00 p.m. in the Yucca Room of the Yucca Valley Community Center.

ADJOURNMENT

There being no further business, the meeting was adjourned at 7:00 p.m.

Respectfully submitted,

Lesley Copeland, CMC
Deputy Town Clerk

**TOWN OF YUCCA VALLEY
PLANNING COMMISSION MEETING MINUTES
MARCH 11, 2014**

Chair Humphreville called the regular meeting of the Yucca Valley Planning commission to order at 6:00p.m.

Commissioners present were Bridenstine, Drozd, Lavender, Whitten and Chair Humphreville.

Pledge of Allegiance was led by Chair Humphreville

APPROVAL OF AGENDA

Commissioner Bridenstine moved to approve the agenda. Commissioner Whitten seconded. Motion carried unanimously.

PUBLIC COMMENTS

None

PUBLIC HEARINGS

- 1. CONDITIONAL USE PERMIT, CUP 02-04 AMENDMENT #1 PANDA EXPRESS-TACO BELL TENTATIVE PARCEL MAP, TPM 19525 ENVIRONMENTAL ASSESSMENT, EA 04-13 EIR STATE CLEARINGHOUSE #2004071127**

Proposal to subdivide approximately 26 acres of commercially zoned property into three parcels of 0.84 acre, 0.75 acre and 23.88 acres and to construct a 2,230 square foot Panda Express and a 2,423 square foot Taco Bell. A total of 51 onsite parking spaces are proposed with drive aisles. The property is located at the south east corner of SR 62 and Avalon Avenue and is also described as Assessor Parcel Number 601-201-37.

The review and approval of the Yucca Valley Retail Specific Plan included a project Environmental Impact Report (EIR), State Clearinghouse #2004071127. The EIR evaluated future projects within the boundaries of the Yucca Valley Retail Specific Plan. The proposed project was evaluated to determine if additional CEQA documentation needed to be prepared. The proposed project will not have any effects not considered within the scope of the program EIR. The project is consistent with project EIR and will not create any additional impacts not previously considered. No additional environmental review is required.

Deputy Town Manager Stueckle gave a staff report and PowerPoint presentation outlining the project. The proposed project involves dividing a 26 acre lot into 3 parcels, two of which will be slightly less than one acre with the Super Wal-Mart retaining a 23.88 acre parcel, and the construction of a 2,230 sq ft Panda Express and a 2,423 sq ft Taco Bell with onsite parking allocated to each of the individual uses. It was the staff's finding that the project is included in the previously completed EIR for the Super Wal-Mart project. It will be attached to the existed Walmart package treatment plat, and the zoning is consistent with the Town's General Plan land use designations.

Deputy Town Manager Stueckle went on to explain that the site plan had be revised based on the discussions with staff. The site plan does not include any direct access to either Twentynine Palms Highway or Avalon Avenue. It does contain the two points of access mandated by the San Bernardino County Fire Department, but due to grade and other constraints, the driveways are located close together on the north side of the site. The revised site plan contains a separate exit for the drive-thru in response to staff's concerns about pedestrian access in the original site plan.

Deputy Town Manager Stueckle also spoke briefly about the proposed architecture. The building height at the top of the parapet for Panda Express is approximately 22ft, and 22ft at top of the tower element for Taco Bell. The one design concern expressed by staff is due to the fact that the trash enclosure is located farther from the buildings than is usual and is in a more visible location. Staff has asked that more additional decorative elements, such a wrought iron, be included than is typically seen around trash enclosures. The applicant also submitted a revised grading and drainage plan in line with the revised site plan.

Staff recommended that the Planning Commission finds the project exempt from further environmental review, and approves both the Conditional Use Permit, CUP 02-04, and the Tentative Parcel Map, TPM 19525, based upon the findings and Conditions of Approval.

Chairman Humphreville invited the representatives of the applicants to speak. Gary Wang of Gary Wang and Associates, the architect for Panda Express, and Charlie Shen from CFT Developments, LLC both offered to answer any of the Commission's questions.

Commissioner Bridenstine asked about the relative lack parking close to the entrance to the Panda Express in comparison to the parking near the Taco Bell. She also asked if there was information about what percentage of Panda Express customers use the drive-thru rather than the dining area.

Charlie Shen replied that the percentage of customers using the drive-thru is usually between 30-60% depending on location and other factors. He said that more detailed information can be provided. Gary Wang also stated that they will include pedestrian crossing hash marks to help protect customers crossing between the parking areas.

Commissioner Whitten commented that in his experience Panda Express tended to have fewer sit down customers than Taco Bell. He also asked about a stop sign at the end of the drive-thru, and speed limit signs.

Gary Wang replied that they were intending to include some kind of traffic control device such as stop signs or speed bumps.

Deputy Town Manager Stueckle stated that the Town does not typically regulated on site driving speeds limits. It is more typical to use stop signs and pedestrian cross walks to regulate on site traffic rather than speed limit signs.

Commissioner Whitten asked about some other options for positioning the drive-thru exit. Mr Wang and Mr. Shen explained that because of a combination of grading issues and issues with Wal-Mart the alternative positions of drive-thru weren't possible.

Commissioner Whitten also asked about the silting basin, and was informed by Mr. Wang that project will be tied into the existing lines.

Chairman Humphreville asked if the applicants intended to include the wrought iron decorative elements on the trash enclosure, and Commissioner Drozd asked what kind of wrought iron décor they intend to include.

Mr. Wang replied that they do intend to include the requested decorative elements, and the décor will fit the theme of the shopping center.

Commissioner Drozd asked for clarification on whether the Environmental Assessment was number EA 04-13 or 05-13. Deputy Town Manager Stueckle replied that the EA 04-13 number was a typo in the packet and EA 05-13 was the correct designation.

Commissioner Lavender asked if the landscaping was being designed with water conservation issues such as permeable surfaces in mind.

Mr. Wang replied that staff had informed them of these concerns and the landscaping is being designed with them in mind.

With no further question for the applicants from the Commission, Chairman Humphreville opened the floor to Public Comment

PUBLIC COMMENTS

Margo Sturges, Yucca Valley, expressed concerned over water usage and how that is being addressed. She wished to know if the Planning Commission has made sure that these issues are being addressed.

Deputy Town Manager Stueckle replied on behalf of staff that both projects are attached to the packaged treatment plant, and that no new facilities will be constructed.

With no further speakers, Chairman Humphreville closed public comments.

Commissioner Whitten moved to find the project exempt from further environmental review, and approve both the Conditional Use Permit, CUP 02-04, and the Tentative Parcel Map, TPM 19525, based upon the findings and Conditions of Approval. Chairman Humphreville seconded the motion. The motion carried unanimously.

2. DEVELOPMENT CODE UPDATE ARTICLE 3

Proposed amendment to Title 9, Yucca Valley Development Code adding Article 3, Chapter 9.30 thru Chapter 9.46, General Development Standards, providing standards for Dedications and Infrastructure Improvements, Landscaping, Parking, Performance Standards, Property Maintenance, Sign Regulations, Soil Erosion and Dust Control, Temporary Special Events, Temporary Uses, Surface Mining and Land Reclamation, Trip Reduction, Accessory Energy Systems, Wireless Communication Facilities, and Cemeteries and repealing Municipal Code Sections 41.151 thru 41.1569 and Development Code Sections 84.0701 thru 84.0740, 87.0201 thru 87.220, 87.0401 thru 87.0405, 87.0505, 87.0601 thru 87.0645, 87.0710 thru 87.07190, 87.0901 thru 87.0940, 88.0805 thru 88.0810, 810.0101 thru 810.0135, 810.0201 thru 810.0275, and 9.75.010 thru 9.75.130.

Deputy Town Manager Stueckle presented the staff report. This meeting was intended as a refresher on the issues which need to be addressed by the Planning Commission so that staff can draft final changes for the proposed amendments to Title 9, Yucca Valley Development Code adding Article 3, Chapter 9.30 thru Chapter 9.46, and staff requested a commissioner dialogue on these issues. Staff would also like to put sign regulations on hold during this process as they should be treated as their own item. The Chapters in question and the areas in particular need of discussion are:

- Chapter 9.30 Dedication and Infrastructure Improvements
 - Staff asks that the Commission discuss the issues associated with what lot sizes require paved access roads, as well as non-residential requirements for full access including streetlights.
- Chapter 9.31 General Development Standards
 - Staff asks that the Commission discuss the issues associated with the exemptions to building height restrictions in the standards for the clear sight triangle.
- Chapter 9.32 Landscaping and Water Conservation
 - There is a new state law in effect mandating an update to city and county water ordinances. Staff drafted language that states that as long as the Water District is undergoing the technical analysis of that portion of the law, the town is not going to duplicate that effort. There is a question of how much landscaping, if any, is going to be required for new development.
- Chapter 9.33 Parking and Loading Regulations
- Chapter 9.34 Performance Standards
 - Several elements in this section were based on county codes, and staff is in the process of going over them with the county to ascertain their applicability to this community.
- Chapter 9.35 Property Maintenance Standards
 - There was a previous discussion regarding the need to provide the necessary flexibility without creating an over enforcement problem.
- Chapter 9.36 Sign Regulations
- Chapter 9.37 Soil Erosion and Dust Control
 - Staff has attempted to minimize the number of regulations and to leave the language more general to allow for a more case by case basis.
- Chapter 9.38 Temporary Special Events
 - Commission may wish to consider if there are additional types of special events which need to be included in the regulations, or any changes in the time limits which may need to be made.
- Chapter 9.39 Temporary Uses and Structures
 - There is more staff work to be done in this area
- Chapter 9.40 Surface Mining and Land Reclamation
- Chapter 9.41 Trip Reduction Requirements
- Chapter 9.42 Accessory Solar Energy Systems
- Chapter 9.43 Accessory Wind Energy Systems
- Chapter 9.44 Wireless Communications Facilities
 - Staff has identified some situations where the process may be simplified.
- Chapter 9.45 Cemeteries
- Chapter 9.46 Renewable Energy Generation Facilities

After the conclusion of the staff's report, Chairman Humphreville opened the floor to public comment.

PUBLIC COMMENTS

Margo Sturges, Yucca Valley, commented on Chapter 9.30.050, Delayed Improvements in Bonding. Ms. Sturges stated that it was her belief that the AMPM facility was given certificate of occupancy before all conditions of occupancy were met, and that it is currently an unsafe set up. She objects to the ability to wave or delay requirements, as decisions made may not follow the guidelines requiring that it not effect health or safety.

Deputy Town Manager Stueckle spoke in response the public comments. He stated that there was no waiver of requirements of conditions of occupancy for the AMPM. The only improvements that were not completed were Cal-Trans projects. The staff may agree with the public comment in some sections of the code. There is a legal requirement to require more than one kind of performance guarantee.

With no further speakers, Chairman Humphreville closed Public Comments.

Chairman Humphreville opened discussion of Chapter 9.30 with the Commission. There was general Commission consensus on a one acre minimum requirement for paved road access.

Commissioner Whitten asked if this section would be the appropriate section to address the issue of what improvements the Town will and won't make to private roads.

Deputy Town Manager Stueckle replied that this section authorizes the Commission to require easements, but does not go into the specifics of whether they are publicly or privately maintained, and that language is not located anywhere within the draft code at this point. The current system was inherited from San Bernardino County and considers roads that were not constructed up to county standards as private roads and were not accepted into the County's maintained road system. Commissioner Whitten believes that this approach needs to be documented in the code language.

Deputy Town Manager Stueckle also pointed out that there have been several subdivisions of 2.5 acres which have roads on 3 or 4 sides and a requirement of dedication of easements for public purposes, but as the density was less than one unit per acre, there was no requirement to create improvements, and the roads are privately maintained. Previously there has not been the requirement for a formal type of district; there is just a requirement of a map notation that the property owner is responsible for those roads. This may be an issue to be addressed in the code.

Commissioner Whitten expressed concern over the issues raised by the proposed repairs to Blackrock Road, and called for documentation in the code to prevent an all or nothing scenario. Chairman Humphreville asked if this is the section where language addressing this issue could be included.

Deputy Town Manager Stueckle replied that he would need to look at this element more closely, but this is probably the correct section. One issue that has come up before is that it would be nice if there was a way to draw a line in the sand so that we are communicating that the roads outside this line are always going to be privately maintained.

Commissioner Bridenstine raised the issue of streetlights. It was her belief that the commission had agreed that streetlights were necessary in a limited amount for safety at the entrance of subdivision or the intersection of a major arterial. She believes there may need to be a qualifier included in the language.

Chairman Humphreville asked if the current code language would allow a new subdivision to put in street lights if they wanted to. Deputy Town Manager Stueckle replied that under the current code language they would not be allowed to put in street lights. However as far as the spacing issue, implementation is

different than the standards, and that standard may need to be modified to reflect current practice. Chairman Humphreville believes this issue may need further discussion.

Commissioner Lavender stated that putting too many conditions on things may limit community development.

Chairman Humphreville introduced a discussion on Chapter 9.31, General Development Standards. He believes that the Commission had previously had a discussion on the issue of building height issue and agreed upon a standard in which a lot of three quarters of an acre or less would be allowed 10% rather than 25 feet. Deputy Town Manager Stueckle stated that they will go back and read those minutes.

Commissioner Whitten asked if the Clear Sight Triangle standards apply to private roads.

Deputy Town Manager Stueckle replied that under current practice Clear Sight Triangle does not apply because the town does not exercise dominion or control of non-maintained roads. Commissioner Lavender commented that on these roads it is difficult to locate the Clear Sight Triangle because the roads themselves are hard to find.

Commissioner Bridenstine brought up the issue of parking lot exits along busy roads, and asked if the Clear Sight Triangle standards should be applied to parking lot entrances. Deputy Town Manager Stueckle stated that there is language that states that the Clear Sight Triangle standards apply to driveways, but it may need to be expanded. Commissioner Bridenstine said that she believes the language should be expanded to more specifically address the commercial driveway.

Commissioner Bridenstine asked how bushes and the like that obstruct the Clear Sight Triangle are dealt with. Deputy Town Manager Stueckle responded that Code Enforcement addresses some issues, while the Public Works crew addresses others.

Commissioner Drozd commented on Chapter 9.32. Mr. Drozd asked about how the total landscape area as referenced in the code was calculated. Deputy Town Manager Stueckle provided a brief answer and reminded the Commission that the standards the Town uses come from state regulations. He stated that Staff is satisfied with the commercial requirements, but would like the Commission's input on whether or there should be minimum standards for new single family residential subdivisions and for infill single family development.

Chairman Humphreville spoke on the issue of landscaping. He believes that the Hi-Water District does a good job of penalizing landscaping that is not drought tolerant through their tiered rate system. He agrees that standards for commercial landscaping should be in place. It is his feeling that there shouldn't be minimum standards of landscaping for residential lots in small subdivisions. He believes that developers are going to do what is necessary to sell lots, and that they should penalize new home buyers who may not be aware of standards when they change the landscaping.

Commissioner Bridenstine agrees with Chairman Humphreville for the most part, but does have some concerns that where there are issues of erosion control there should be some kind of standards. She also brought up the monotony of the landscaping in the Copper Hills track. Chairman Humphreville agreed that minimum standards might encourage minimum standard landscaping. Commissioner Bridenstine also stated that if you require the developer to provide landscaping it will be the cheapest and easiest option as opposed to a home owner, and perhaps the home owner should be required to do something. She also reiterated that there is a big erosion problem, and that needs to be taken into account.

Commissioner Whitten spoke about sewer project, and asked what the Water District's plans are in regards to reclaimed treated water including the possibility of including a purple pipe system in the Town to tap into treated water for irrigation needs. He also believes that drought tolerance and permeable surfaces are important elements. He said he did not see those terms in the section. He also asked if there were ways we can allow developers to innovate and use newer technologies.

Deputy Town Manager Stueckle responded by explaining that the Water District's plan does not currently allow for the use of treated water for irrigation. There were a number of discussions with the Water District about the feasibility of a purple pipe system, but it was highly cost prohibitive. As far as staff is aware the treated water will be used for recharging the aquifer. He also stated that there is room for language regarding drought tolerance, permeable surfaces, catch basins and the like. Chairman Humphreville added that the Water District quoted five million dollars just for the installation of a purple pipe from the treatment facility to the golf course.

Commissioner Bridenstine asked if regulations allow for the use of grey water for irrigation. Deputy Town Manager Stueckle believes that state law allows for the use of grey water in irrigation as long as the water does not come above ground, but it was his understanding that the technology did not make it a very effective method for many property owners. Commissioner Bridenstine stated that she believes that the technology has improved.

Chairman Humphreville added that he has installed grey water irrigation systems in homes during new construction and that in the past there have been programs through the Water District that help subsidize those installations, and that funding may still be available. Commissioner Whitten asked if the new water efficient appliances would have any effect on the usefulness of grey water systems. Chairman Humphreville said that washers and showers are the largest generators of grey water, and believes that if the Water District grey water program is still available, other programs should not be mandated. Both Commissioners Bridenstine and Whitten agreed that there should not be mandates put into place, but that the information about options should be made available in the code.

Chairman Humphreville introduced a discussion of Chapter 9.33, Parking and Loading Regulations. He stated that he believed he had had a previous conversation with Deputy Town Manager Stueckle about the number of parking spaces required for golf courses under the current code. He believes that six spaces per hole is excessive.

Commissioner Bridenstine raised the issue that the ordinance does not currently address parking at parks and also asked if there has been a discussion about using shared parking facilities for businesses that can share parking due to situations such as separation of hours. Deputy Town Manager Stueckle replied that staff will look at the parking regulations to make sure that parks are adequately addressed and that staff agrees the shared parking concept should be included and that if there is not adequate language in the code, it should be added.

Commissioner Whitten said that we need to address RV parking and the space calculations of two parking spaces for single family dwellings. Two parking spaces may not be enough given current driving practices.

Deputy Town Manager Stueckle asked that the Commission talk about what they envision for RV parking regulations, both commercial and residential. He also said that it is common for a family to have more vehicles than fit in a two car carport or garage. The Town of Yucca Valley does not have any regulations that limit the number of vehicles which can be parked on a lot outside of the covered spaces. Commissioner Whitten asked for confirmation that minimum two space requirement did not include driveway parking, which Deputy Town Manager Stueckle provided. Commissioner Whitten also stated

that he felt they need to separate non-operational and operational vehicle parking in uncovered spaces in the code.

Commissioner Whitten stated that he felt there should be some kinds of standards for covered RV parking in residential areas. He also said that commercial parking that allows RVs to park in their lots overnight, such as Wal-Mart, should be required to have dedicated parking spaces, rather than allowing the RVs to park across multiple spaces.

Commissioner Bridenstine added that she does not feel that RVs should be required to be kept in a covered parking space. Commissioner Whitten clarified that he didn't think covered parking should be required but given as an option. Commissioner Bridenstine felt that the construction of covered RV parking would fall under an auxiliary structure ordinance rather than a parking ordinance. She felt that the Town should be wary of putting too many restrictions on the parking of RVs. Chairman Humphreville agreed that RV parking should be allowed on lots, but added that it should be restricted on the street. He also expressed concern over square footage restrictions for garages causing bad design elements.

Commissioner Whitten said that he feel that RV parking on smaller lots is problematic. He said in the Copper Hills development there are RV's parked in front yards, not in parking spaces or backyards. He feels that this needs to be addressed for certain sizes of lots. Chairman Humphreville asked if that is something that could be included in the CC&Rs for new subdivision development. Deputy Town Manager Stueckle explained that there are currently subdivisions with CC&Rs in place, but there are no longer homeowner associations enforcing those CC&Rs, and the Town cannot enforce CC&Rs. Deputy Town Manager Stueckle believes that this issue involves multiple code elements, including auxiliary structures and subdivision design. He also said that we need to be looking at what the appropriate lot size is for side yard access for recreational vehicles in subdivisions. Chairman Humphreville suggested that subdivisions with smaller lot sizes include a shared recreational vehicle parking area. Commissioner Whitten agreed that that is something that should potentially be included in the code. Commissioner Whitten also brought up the concern that RV parking in yards can cause damage to septic tanks.

Chairman Humphreville asked for any comments from the commissioners on the Performance Standards section of the code. Receiving none he moved on to the Property Maintenance Standards.

Chairman Humphreville and Commissioner Whitten agreed that Property Maintenance Standards should be complaint driven. Commissioner Whitten asked if there was any way to incorporate some kind of objective severity standards into the code language in cases such as damage to screen doors. Deputy Town Manager Stueckle said that that might be difficult language to draft. Commissioner Whitten also asked how someone was supposed to determine if a roof is leaking from the street. Deputy Town Manager Stueckle explained that that section of the code was usually applied when there are large sections of roofing material missing, or a tarp which has been in place for several months. Commissioner Bridenstine also expressed concern over the lack of severity standards in the case of cracked stucco, given that environmental factors cause a general amount of wear and tear.

Chairman Humphreville reported on the work he had been doing on the sign ordinance issue. He has had multiple meetings with businesses and the Chamber of Commerce, and doesn't think there are any options that will make everyone happy. He had three proposed changes that he would like the Commission to consider. First, for 0 to 7,500 square feet, adding a 10% increase in sign size on buildings. Secondly for 7,500 to 20,000 square feet, adding a 10% increase in signage on the building and/or a second monument sign. Finally, in the larger shopping centers, adding a second monument sign with a spacing requirement would allow more business to have highway frontage signage. The Commission came to a consensus that business community's input is needed on this issue, and that the Commission should hold a workshop on this issue.

Chairman Humphreville called a brief recess, after which the meeting resumed.

Chairman Humphreville introduced a discussion of Chapter 9.37, Soil Erosion and Dust Control. He commented that in his experience the biggest problem with dust is caused by the baseball fields. Deputy Town Manager Stueckle informed the commission that the town mixes clay into its fields to keep the dust down and the clay has currently worn down to a minimal level. Once the clay is reintroduced the dust issue will be greatly reduced. Commissioner Whitten asked if there were any issues with the Mohave Desert Air Quality Management District. Deputy Town Manger Stueckle said that the Mohave Desert Air Quality Management District waves dust control issues when the wind rises above certain speeds.

Chairman Humphreville introduced a discussion of Chapter 9.38, Temporary Special Events. Commissioner Drozd asked about the limited number of church revival events allowed per year compared with some of the other activities. He felt that the number should perhaps be higher. Commissioner Whitten said that he thought that special events were good for the community and there shouldn't be a maximum number imposed. Instead the limit should be dependent on staff time. Deputy Town Manger Stueckle was asked to explain the reasoning behind the current limits. He explained that the goal of the limits was to prevent a semi-permanent activity occurring on a site without any improvements being made. In the current ordinance the number of events is high, and it runs by location rather than the organization involved. Chairman Humphreville asked if a location has ever reached the maximum number of allowed events, and was informed that no location ever has. Chairman Humphreville suggested that instead of a maximum number, it becomes a complaint driven issue, but also suggested waiting until it is an issue. Commissioner Bridenstine suggested that maximum limits could be at the director's discretion.

Commissioner Drozd said he does see a reason to limit the number of yard sale type activities allowed at a location. Deputy Town Manager Stueckle said that the consultant when they were originally drafting this ordinance suggested limiting the number of garages sales and requiring permits, but the Town has so far chosen not to peruse that option. Commissioners Drozd, Humphreville and Whitten do not want to require permits for yard sales

Commissioner Whitten asked what the Yucca Valley Swap Meet was operating as. Deputy Town Manager Stueckle explained that that particular use has been going on for a long period of time, but under current standards it would fall under the code regulating swap meets. Diane Olsen read out the relevant section of code. There was a general consensus among the commission that some form of those regulations should be included in Chapter 9.38. Commissioner Lavender said that he doesn't want to outlaw yard sales. Commissioner Whitten asked if advertised estate sales or auctions would fall under special events or garage sales. Chairman Humphreville asked for and received confirmation that under the current ordinances there are options for code enforcement if there are complaints.

Chairman Humphreville introduced a discussion of Chapter 9.39, Temporary Uses. Commissioner Bridenstine asked if this is the section of the ordinances which should govern temporary storage pods. She provided an example of a business which was denied the use of temporary storage pods while is property was undergoing repairs. Deputy Town Manager Stueckle said that that kind of permit is usually attached to a building permit. Staff agreed to look at the code and see if language needs to be included to cover situations where no building permit is required.

Commissioner Whitten asked about individuals camping on property while it is being built or repaired. Deputy Town Manager Stueckle said that the current practice is that the Town issues a temporary use permit for temporary occupancy on the property as part of the building permit, and that staff will make sure that language is in the code.

Chairman Humphreville asked for any comments on 9.40, Surface Mining and Land Reclamation. Commissioner Drozd asked if that language could be removed from the code. Deputy Town Manager Stueckle said that staff would have to find out if removing that language is allowable under state law.

Chairman Humphreville introduced a discussion on Chapter 9.41, Trip Reduction Requirements, and asked if the current ordinances meet state requirements. Deputy Town Manager Stueckle said that the current ordinances do meet state requirements and that the current standards could be considered minimal. Commissioner Whitten asked if including common storage areas in subdivisions would involve trip reduction requirements. Deputy Town Manager Stueckle, said that it was unlikely except if a large enough subdivision was built. Those kind of improvements are unlikely in smaller subdivisions.

Chairman Humphreville introduced a discussion on Chapter 9.42, Accessory Solar Energy Systems. Commissioner Whitten spoke about solar easements in the case where neighboring building height may block solar panels. Chairman Humphreville suggested that that issue might be taken care of by changing the allowable height increase to 10%. Deputy Town Manager Stueckle said that this issue may be addressed in Article 2. Chairman Humphreville brought up new developments that are being constructed as solar ready, and asked if any kinds of requirement should be added to screen those elements. He also said that it was his understanding that the state limits what kind so restrictions can be put on conversion of existing structures.

Chairman Humphreville introduced Chapter 9.43, Accessory Wind Energy Systems, and said he is happy with the one acre minimum requirement. Commissioner Bridenstine agreed. Commissioner Whitten said that there are systems now that can fit on a parcel smaller than one acre, and do not rise very high above the roof line. Commissioner Bridenstine said that the current regulations are not keeping property owners from using alternative energy sources, they are just stating that some parcels are better suited to wind or solar. Commissioner Whitten said that he believes that the technology for wind generation has improved and that the current ordinance takes away options. Chairman Humphreville brought up the possibility of a limit based on decibel level at the property line, but said that this solution would address the problem of view obstruction. Commissioner Bridenstine agreed that there would still be a problem with view obstruction. Chairman Humphreville suggested leaving the ordinance as it is and returning to it again if the demand for wind turbines increases. Commissioner Whitten believes that there should be some mechanism for exceptions in the code. Commissioner Bridenstine believes that having an ordinance in places gives the Town the tools to protect the viewshed. Commissioner Whitten suggested looking at the Twentynine Palms mechanism as an alternative which might create more flexibility. Commissioner Lavender asked if Building and Safety was involved in determining whether or not solar systems were a scam. Deputy Town Manger Stueckle responded that Building and Safety checks the safety of the connections but does not oversee the efficiency of the systems themselves.

Chairman Humphreville asked for comments on Chapter 9.44, Wireless Communication Facilities, and was informed by Deputy Town Manager Stueckle that the commission take into account that there are some elements that staff would like to make some further changes to, but that the ordinances is mostly solid.

Chairman Humphreville asked if there were any comments on Chapter 9.45, Cemeteries. There were none.

Chairman Humphreville asked if there were any comments on Chapter 9.46, Renewable Energy Generation Facilities. There were none.

Deputy Town Manager Stueckle thanked the Commission, on behalf of the staff, for its input on this issue. Staff will take direction from the Commission's previous minutes, as well as notes from this

meeting, and make revisions. The staff recommends that the Planning Commission continues the public hearing to the March 25, 2014 Planning Commission meeting to allow staff to make final changes for Commission consideration.

Commissioner Whitten moved that the Commission continue the public hearing to the March 25th, 2014 Planning Commission meeting to allow staff to make final changes for Commission consideration. The motion was seconded by Chairman Humphreville and was approved unanimously.

DEPARTMENT REPORTS:

1. HOME OCCUPATION PERMIT REGULATIONS

Deputy Town Manager Stueckle provided the staff report. He reminded the Commission that there had previously been a lengthy discussion of the Home Occupation Permit Regulations over what are appropriate types of home based businesses as the result of home based businesses requesting federal and state firearms licenses. He provided an over view of the current ordinance for the three tiers of home based businesses. Staff would like input from the Commission on the issue of whether or not the ordinances address the physical differences between lots of different sizes, and provided the example of a business on a two and a half acre lot, which is far away from any neighboring structures, having a small amount of outdoor storage. He also acknowledged that due to the late hour, the Commission may choose to continue the discussion on this issue at a later date.

After the conclusion of the staff's report, Chairman Humphreville opened the floor to public comment.

PUBLIC COMMENTS

Margo Sturges, Yucca Valley, is concerned over this issue and believes this is a topic that needs to be work shopped. She is feels that selling weapons out of the home in rented locations like apartment complexes may affect the expectation of quiet enjoyment of renters and the liability of a landlord. She believes that the neighborhood dislikes the idea of weapon sales, and it should be limited to large lots.

Chairman Humphreville asked for staff discussion on this issue, and Deputy Town Manager Stueckle said that because this is a complex issue with many elements to be considered, staff believes that this item requires further discussion at a later date.

Chairman Humphreville asked if the ordinance as it is written now gives the town the flexibility to work with the businesses like the earlier example of a home based business on a two and a half acre lot with outside storage. Deputy Town Manager Stueckle replied that under the current ordinances staff was not able to find any way to address this issue, and staff believes there needs to be some modifications to the ordinance.

Commissioner Lavender said that he believes that most Yucca Valley citizens are against residential gun sales.

Commissioner Whitten believes that there should be a workshop, and that regulations need to be changed to reflect the changing climate regarding guns. He also believes that the Town should send a building inspector to make sure a home fits home occupation permit. He also suggest that these permits come to Planning Commission for review, and that permitted operating hours be changed. He believes that 7:00am

is too early and 8:00pm is too late. He also thinks that home animal rescue and home animal care and boarding should be prohibited, and believes that this should be revisited in a workshop.

Commissioner Drozd suggested that arm sales under a certain lot size should prohibit ammunition sales.

There was a consensus among the Commissioners that a workshop in this issue would be appropriate.

Deputy Town Manager Stueckle agreed that this will be revisited at a later date for further discussion.

There was no motion, but there was a consensus to hold a workshop at a later date

CONSENT AGENDA:

1. 2013 GENERAL PLAN ANNUAL REPORT

Government Code Section 65400 mandates that all cities and counties submit to their legislative bodies an annual report on the status of the General Plan and progress on its implementation. The report must then be filed with the state’s Office of Planning and Research (OPR) and the Department of Housing and Community Development (HCD). This annual review addresses the January 1, 2013 through December 31, 2013 time period.

2. MINUTES

A request that the Planning Commission approve as submitted the minutes of the meetings held on October 08, 2013, November 12, 2013 and February 11, 2014.

PUBLIC COMMENTS

None

Commissioner Whitten moved that the Commission approve Consent Agenda items one and two. The motion was seconded by Commissioner Bridenstine and was carried unanimously.

STAFF REPORTS AND COMMENTS:

None

FUTURE AGENDA ITEMS:

Development Code Update - Article 3
Site Plan Review 01-24 – Phase 1 Hawks Landing

COMMISSIONER REPORTS AND REQUESTS:

Commissioner Drozd thanked everyone for their participation.

Commissioner Lavender stated that it was a good discussion and he appreciates that.

Commissioner Whitten said that he wanted to know where adult orientated businesses are covered in the code. Deputy Town Manager Stueckle replied that it is covered in Article 2, and that conversation will be coming forward. Commissioner Whitten also stated that the recent rainstorm may have identified some

drainage issues created by the new medians. Deputy Town Manager Stueckle explained that the Highway intersections with Inca and Fox have historically been the high flood points, and the flooding issues preexists the median project. Staff began looking into options to create some better drainage in that area prior to the median project, and this is an ongoing issue.

Vice Chairman Bridenstine had no further comments.

Chairman Humphreville had no further comments.

ANNOUNCEMENTS:

The next regular meeting of the Yucca Valley Planning Commission will be held on Tuesday, March 25, 2014

ADJOURNMENT

There being no further business, the meeting adjourned at 8:45 p.m.

Respectfully submitted,

Allison Brucker
Secretary

**TOWN OF YUCCA VALLEY
PLANNING COMMISSION MEETING MINUTES
MARCH 25, 2014**

Chair Humphreville called the regular meeting of the Yucca Valley Planning Commission to order at 6:00 p.m. All commissioners were present.

The Pledge of Allegiance was led by Chair Humphreville.

APPROVAL OF AGENDA

Commission Whitten moved to approve the agenda. Vice-Chair Bridenstine seconded.

Motion carried 5-0 on a voice vote.

PUBLIC COMMENTS

None

**1. SITE PLAN REVIEW, SPR 01-14
ENVIRONMENTAL ASSESSMENT, EA 01-14
HAWKS LANDING GOLF CLUB AT BLUE SKIES**

Deputy Town Manager Stueckle presented the staff report for Site Plan Review, SPR 01-14, Environmental Assessment, EA 01-14 for Hawks Landing Golf Club at Blue Skies

The project is a 5,100 square foot replacement clubhouse, to construct a 2,500 square foot maintenance building and paved parking, with a building pad for a future additional clubhouse, parking and ancillary improvements. Sewage disposal is proposed for Phase 1 by connecting to the existing septic tank and leach field systems. Both Phase 1 and Phase 2 buildings will be connected to the future public sewer system when available. Phase II is planned to be served by a new septic system until such time as the HDWD collection and treatment system is available. The proposed project is located at 55100 Martinez Trail and is further identified as AMS's 586-031-36, 594-041-34, and 594-041-35.

Updated conditions of approval were reviewed. The site plan review (SPR 01-14) shall become null and void if construction has not commenced within three years of the approval day of March 25, 2014.

The project was reviewed under the California Environmental Quality Act (CEQA). The project is exempt from CEQA under section 15302, Class 2, replacement or reconstruction of existing facilities.

Cindy Melland, of MJB, Golf, LLC spoke about the project, describing planned elements including a covered patio area and large driving range. A versatile 12-hole design is planned. The 16 acres of irrigated turf is integrated with non-turf, brought resistant landscaping.

Bill Warner, of Nolte V5 continued to give detail on the proposed building plans.

Commissioner Whitten inquired if any additional wildlife studies were required. Stueckle explained that because the project is in the same scope as previous land-use, no further studies were required. Whitten also asked about water run-off and safety features used to protect neighboring properties. Melland explained the course was designed to capture and hold rain water, to allow percolation into the ground. Also, tee boxes were designed to face away from structures. Warner reported that the new driving range design is further away from homes than the prior range.

Vice Chair Bridenstine asked for clarification on the location of the maintenance building in relation to the clubhouse. Warner explained that the maintenance building is off of Yucca Trail, on the east-end of the property.

Chair Humphreville commented favorably on the project.

Chair Humphreville opened public comment. With no members of the public wishing to speak, public comments were closed.

Vice Chair Bridenstine moved to find the project exempt from CEQA under Section 15302, Class 2, replacement or reconstruction of existing facilities, and to approve Site Plan Review, SPR 01-14, based upon the findings and the Conditions of Approval. Chair Humphreville seconded. Motion carried 5-0 on a voice vote.

PUBLIC HEARING

2. DEVELOPMENT CODE AMENDMENT, DCA 07-13 ARTICLE 3

Deputy Town Manager Stueckle recommended that the Planning Commission take public testimony for the advertised public hearing, and to continue the hearing to April 8, 2014 to allow for additional staff review and preparation.

Chair Humphreville opened the public hearing. With no members of the public wishing to speak, Chair Humphreville continued the public hearing to April 8, 2014.

CONSENT AGENDA

MINUTES

Commissioner Whitten moved to approve the Yucca Valley Planning Commission minutes of the meeting held on March 11, 2014. Vice Chair Bridenstine seconded. Motion carried 5-0 on a voice vote.

STAFF REPORTS AND COMMENTS

Deputy Town Manager Stueckle presented a brief updated on private land development projects including the Senior Apartments, Petco and Marshalls. It is anticipated that the third phase of Copper Hills Homes (PM17862) will be in plan check soon. Developers for Ross Dress for Less have applied for a signage variance and will be coming before the Planning Commission in the near future.

FUTURE AGENDA ITEMS

Variance, V-01-04 Ross

COMMISSIONER REPORTS AND REQUESTS

Commissioner Drozd thanked staff.

Commissioner Lavender voiced appreciation for the thorough report on the golf course plans.

Commissioner Whitten: Thanked staff and commented on the new lane striping at the corner of Palomar and Yucca Trail.

Vice Chairman Bridenstine thanked staff and is glad to see the golf course project moving along.

Chair Humphreville also expressed favor to see the golf course project taking shape and thanked staff. Humphreville is hearing positive comments in the community for the efficiency of Town staff.

ANNOUNCEMENTS

The next regular meeting of the Yucca Valley Planning Commission will be held on Tuesday, April 8, 2014.

ADJOURNMENT

There being no further business, Chair Humphreville adjourned the meeting at 6:50 pm.

Respectfully submitted,

Lesley Copeland, CMC
Town Clerk