

Section 5 – Miscellaneous Details

<u>Drawing No.</u>	<u>Description</u>
500	Single Mailbox Installation
501	Multiple Mailbox Installation for New Sidewalk
501A	Multiple Mailbox Installation for Existing Sidewalk
510	Metal Beam Guardrail
511	Metal Plate Guardrail
520	Traffic Safety Markers
521	Post with Reflector
522	End of Street Temporary Pavement
522A	Barricade Rural Area
523	Street Marker Post Installation
530	Standard Trash Enclosure
540	Non Retaining Concrete Blockwall
550	Pipe Swing Gate
M1	Copperweld Monument
M2	Sectional Monuments
M3	Centerline Ties

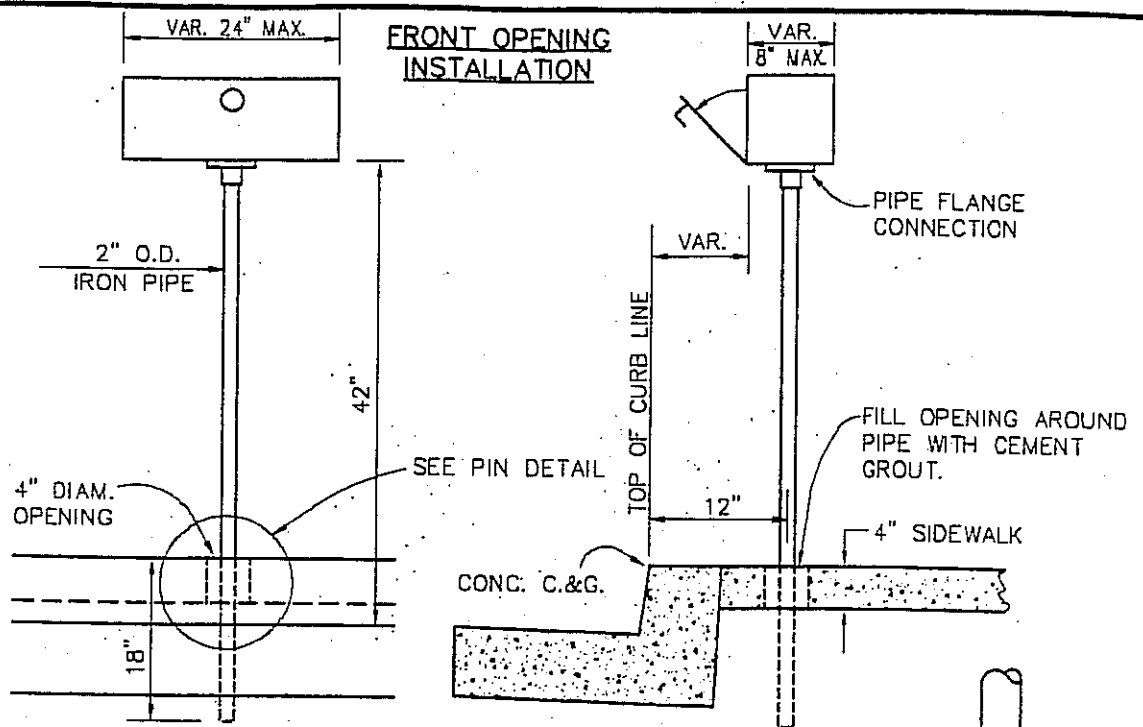

NOTE: END OPENING MAILBOX NOT PERMITTED. FACE OF MAILBOX SHALL NOT EXTEND PAST TOP OF CURB LINE.

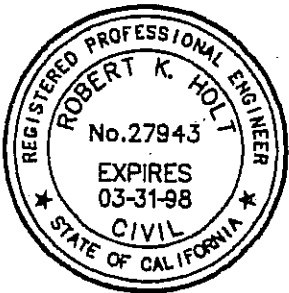
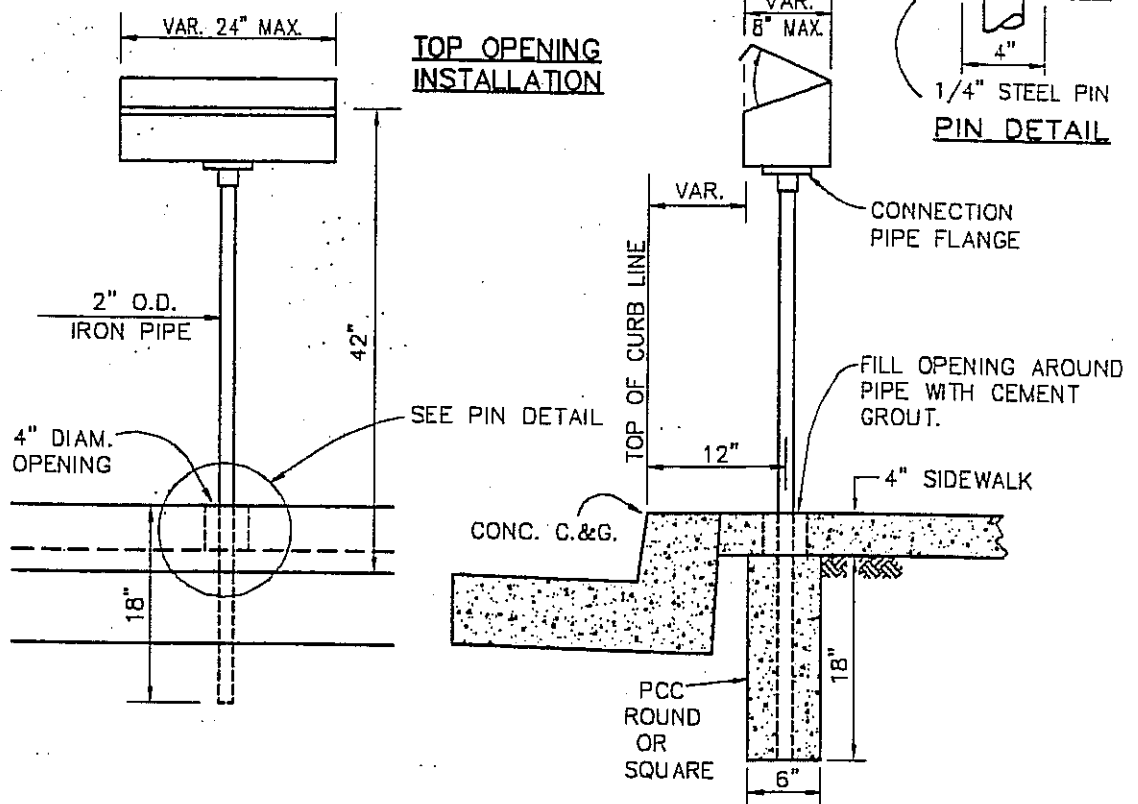

APPROVED: _____ DATE _____

APPROVED: TOWN ENGINEER
Robert K. Holt R.C.E. 27943



Town of
Yucca Valley

SINGLE MAILBOX
 INSTALLATION

REVISION BY DATE

STANDARD DRAWING NO. 500

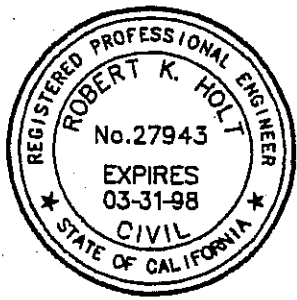
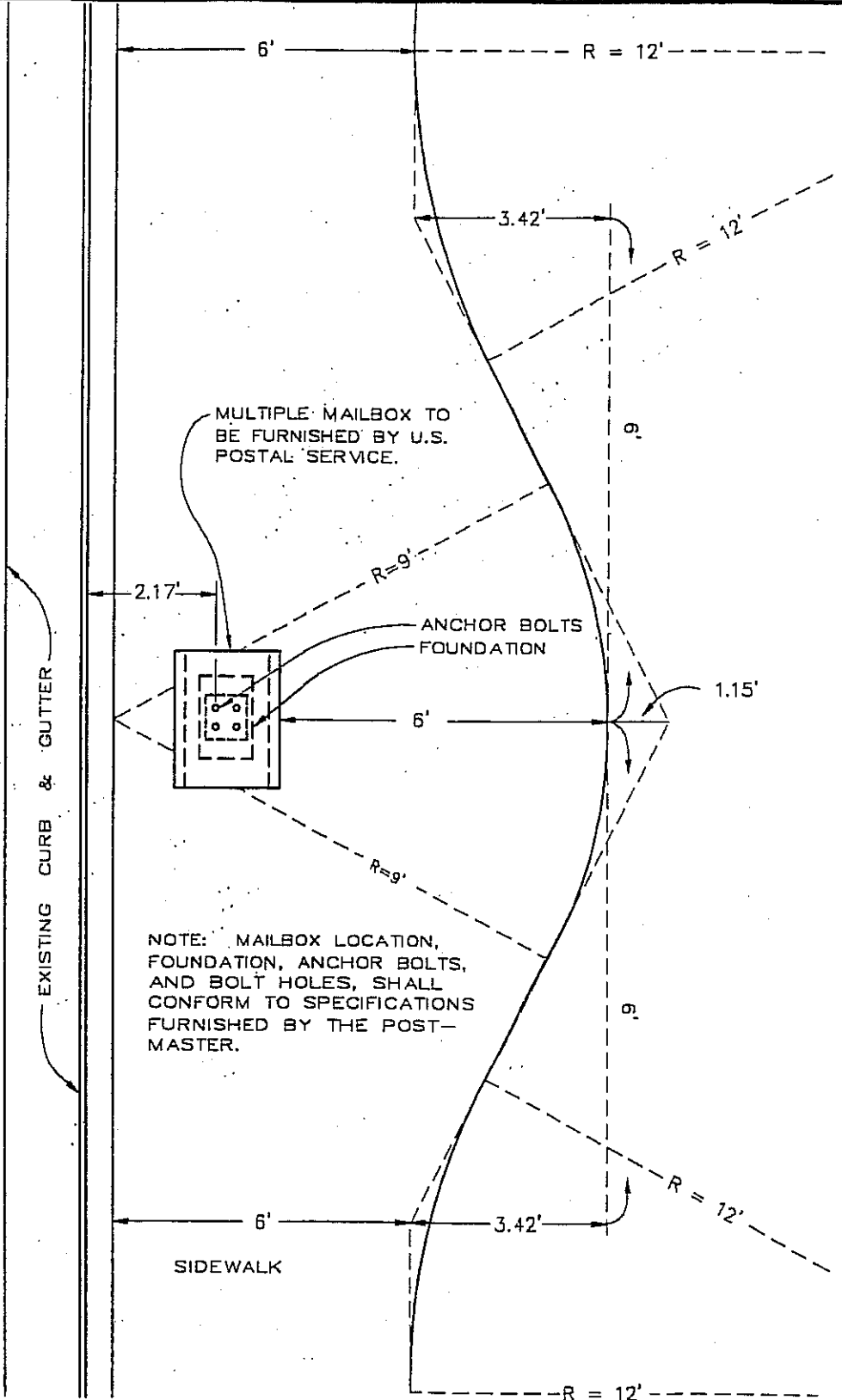

APPROVED: _____ DATE _____

APPROVED: TOWN ENGINEER
Robert K. Holt R.C.E. 27943

REVISION	BY	DATE



Town of
Yucca Valley

MULTIPLE MAILBOX INSTALLATION
 FOR
 NEW SIDEWALK

STANDARD DRAWING NO. 501

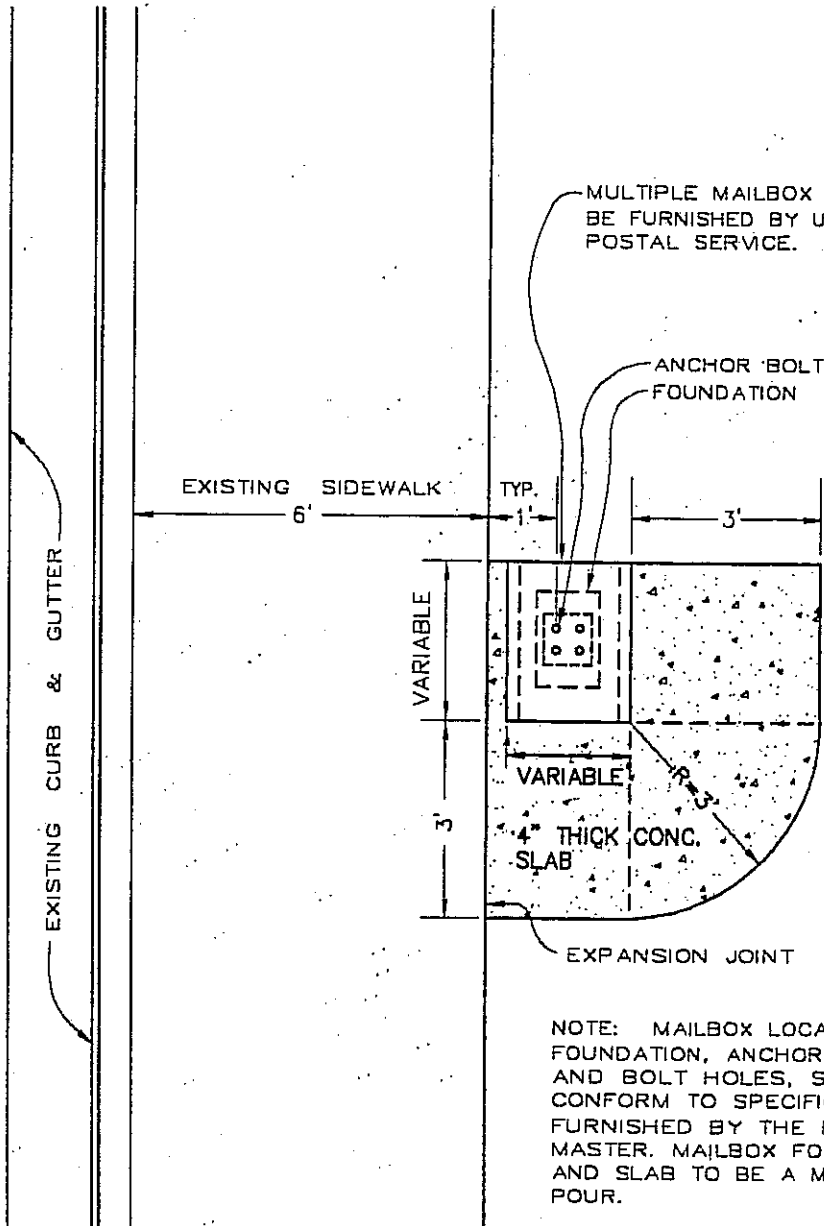

MULTIPLE MAILBOX TO BE FURNISHED BY U.S. POSTAL SERVICE.

ANCHOR BOLTS FOUNDATION

EXISTING SIDEWALK 6' TYP. 1'

EXISTING CURB & GUTTER

VARIABLE

VARIABLE

4" THICK CONC. SLAB

EXPANSION JOINT

NOTE: MAILBOX LOCATION, FOUNDATION, ANCHOR BOLTS, AND BOLT HOLES, SHALL CONFORM TO SPECIFICATIONS FURNISHED BY THE POSTMASTER. MAILBOX FOUNDATION AND SLAB TO BE A MONOLITHIC POUR.

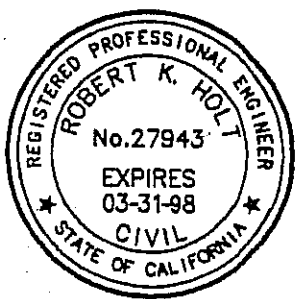

APPROVED: _____ DATE _____

APPROVED: TOWN ENGINEER
Robert K. Holt
 R.C.E. 27943



Town of
Yucca Valley

MULTIPLE MAILBOX INSTALLATION
 FOR
 EXISTING SIDEWALK

REVISION	BY	DATE

STANDARD DRAWING NO. 501A

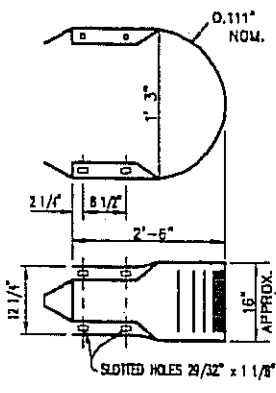

RETURN SECTION

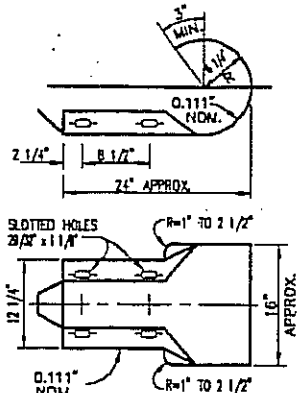

**TERMINAL SECTION
TYPE "A"**

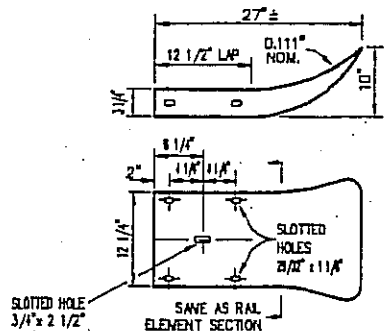

**TERMINAL SECTION
TYPE "B"**

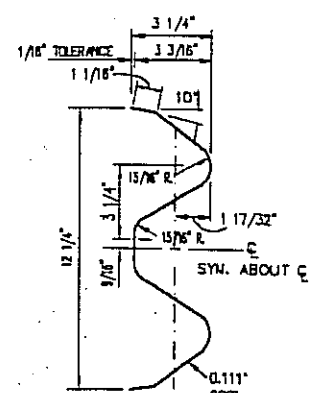

**SECTION THRU
RAIL ELEMENT**

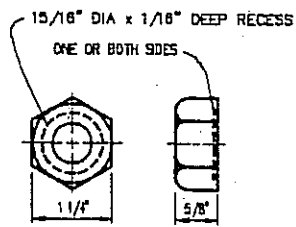

5/8" RECESS NUT

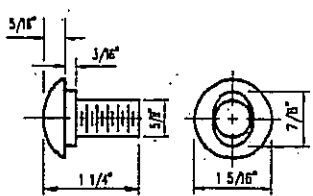

5/8" BUTTON HEAD BOLT

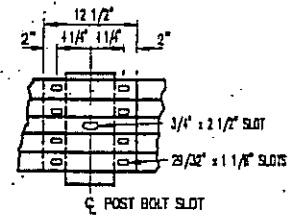

5/8" x 1 1/4" BUTTON HEAD OVAL SHOULDER BOLTS WITH 1/4" RECESSED HEX NUTS TOTAL 8 PER SPLICE AND 4 PER TERMINAL SECTION. LAP IN DIRECTION OF TRAFFIC.

RAIL SPLICE

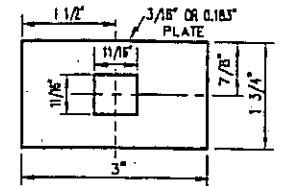

FLAT PLATE WASHER

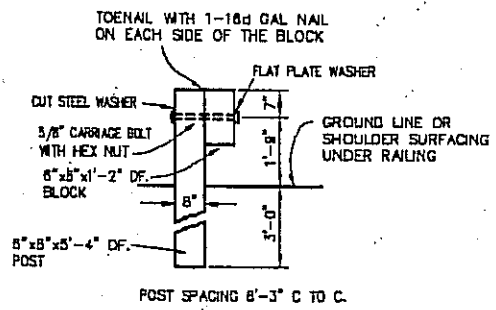

LINE POSTS

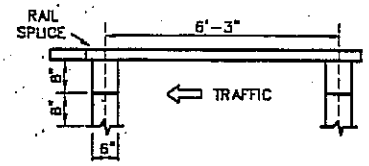

PLAN

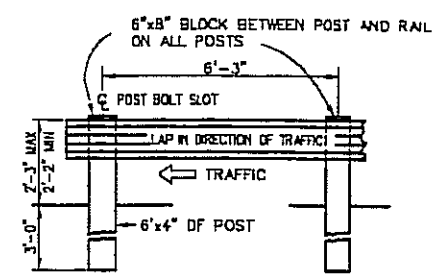

ELEVATION

NOTES:

- 1 CENTER TO CENTER OF THE POSTS SHALL BE 6'-3" UNLESS SHOWN OTHERWISE.
- 2 BACKFILL IN POST HOLES TO BE COMPACTED TO ORIGINAL DENSITY OF SOIL.
- 3 EQUIVALENT DESIGN MAY BE ACCEPTABLE.
- 4 MATERIALS AND CONSTRUCTION SHALL CONFORM TO STATE OF CALIFORNIA, STANDARD SPECIFICATION PLAN A77-CW.

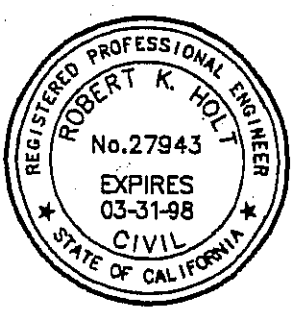

APPROVED:	DATE
APPROVED: TOWN ENGINEER <i>Robert K. Holt</i>	R.C.E. 27943
REVISION	BY DATE



*Town of
Yucca Valley*

**METAL BEAM
GUARDRAIL**

STANDARD DRAWING NO. 510

SIZE: 10 GAGE (.1345)
 12" x 129" OR 159"
 129" = 73.4 LBS.
 159" = 90.7 LBS.

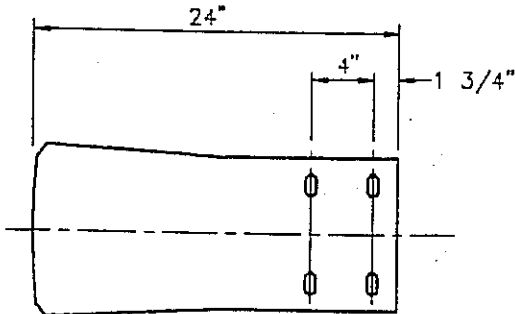
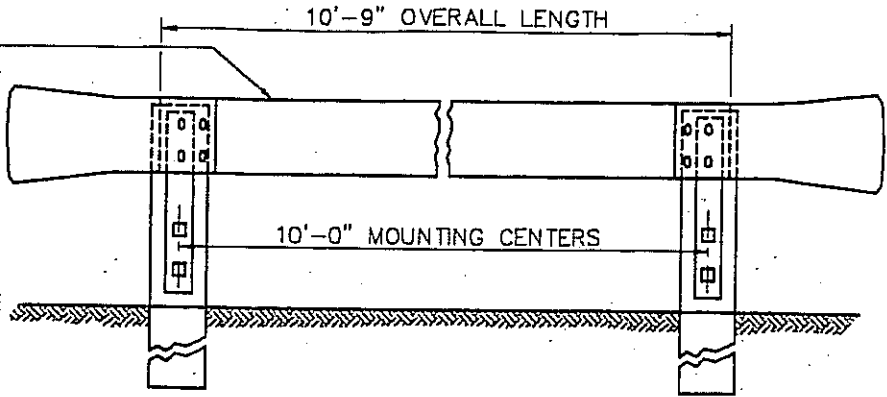

4-SPECIAL 3/4" DIA. 1 5/8" LONG
 BUTTON HEXAGONAL HEAD
 BOLTS AND SQUARE NUTS

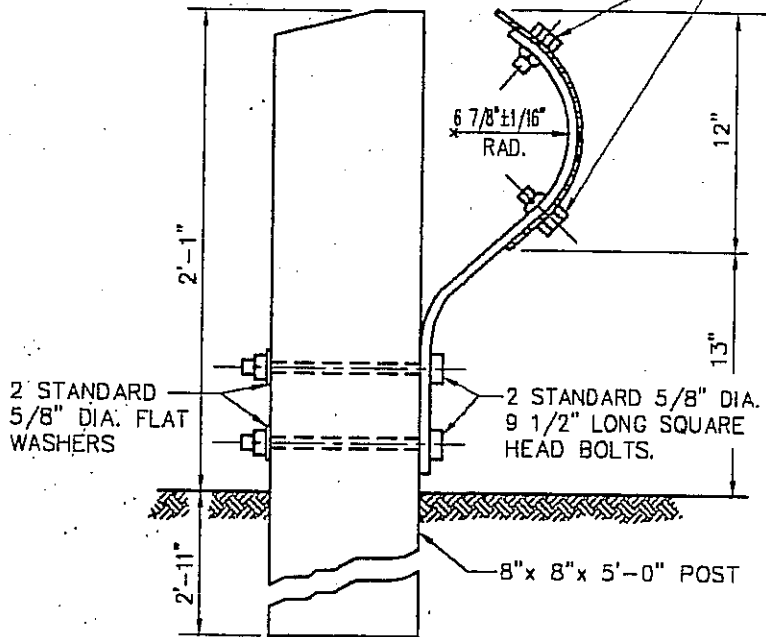
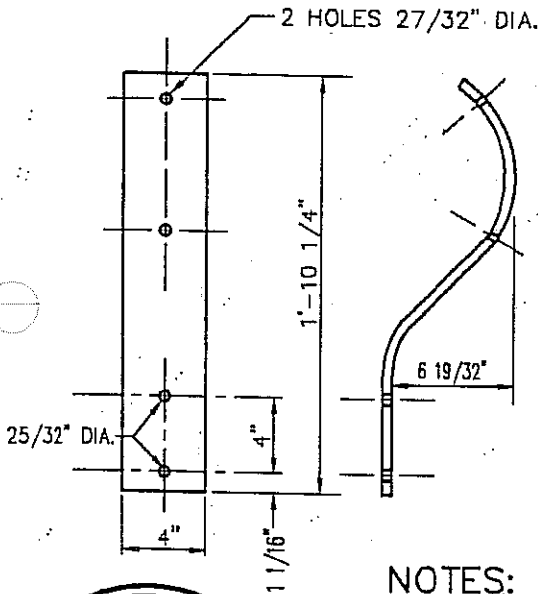

NOTES:

1. POSTS ARE TO BE SET IN SUCH A POSITION THAT THE TOP OF THE GUARD RAIL SHALL BE LEVEL WITH THE TOP OF THE POSTS.
2. BACKFILL IN POST HOLES TO BE COMPACTED TO ORIGINAL DENSITY OF SOIL.
3. EQUIVALENT DESIGN MAY BE ACCEPTABLE.
4. MATERIAL AND CONSTRUCTION SHALL CONFORM TO APPLICABLE SECTIONS OF STATE OF CALIFORNIA STANDARD SPECIFICATIONS, UNLESS SHOWN OTHERWISE.

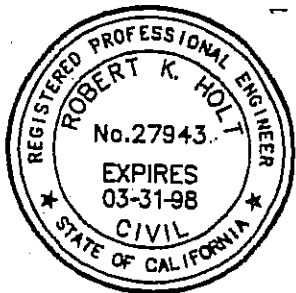

APPROVED:

DATE

APPROVED: TOWN ENGINEER

Robert K. Holt

R.C.E. 27943



Town of
Yucca Valley

METAL PLATE
 GUARDRAIL

REVISION

BY DATE

STANDARD DRAWING NO. 511

SEE NOTES 1 & 2
CENTER MOUNT
REFLECTORS

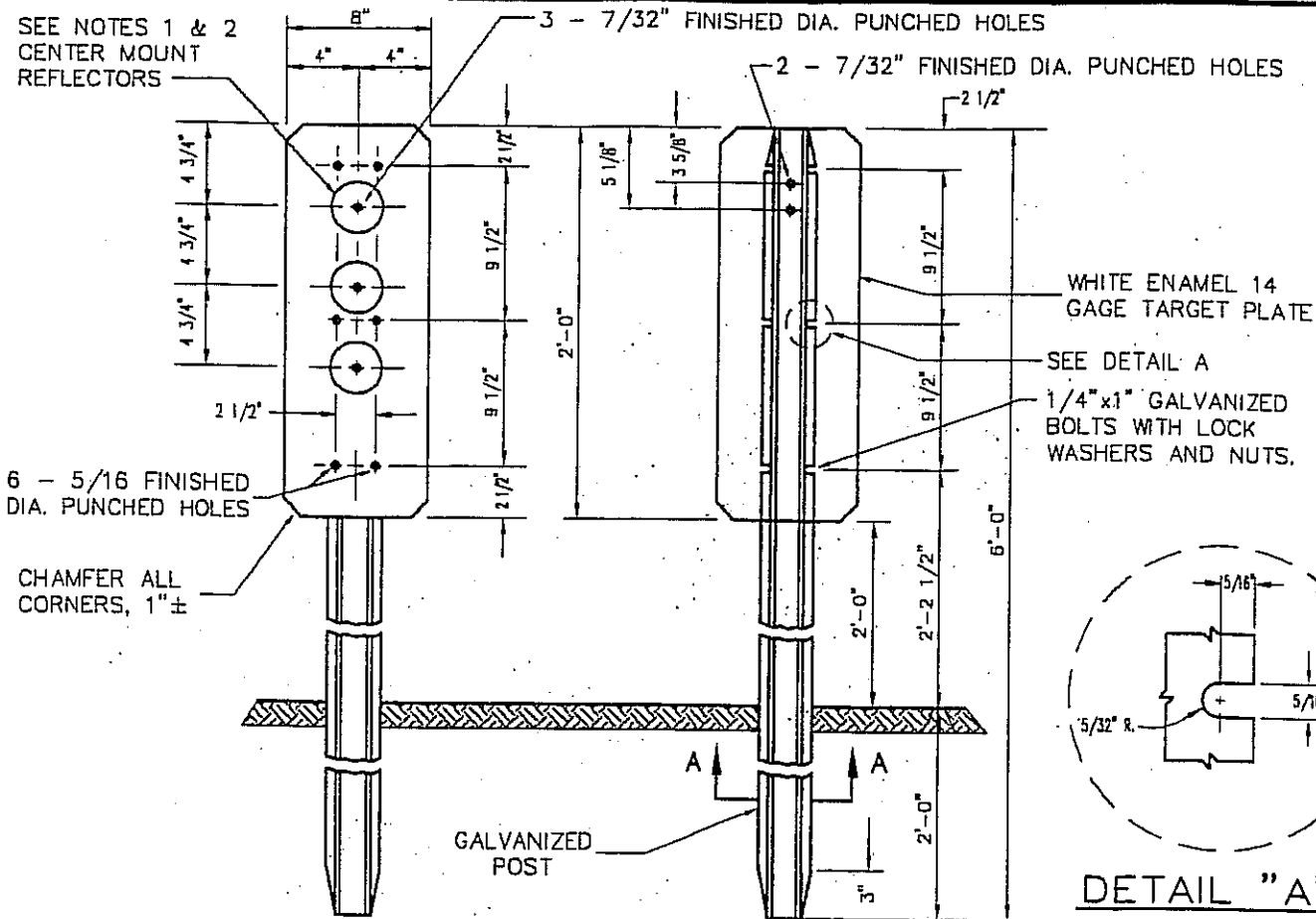

WHITE ENAMEL 14
GAGE TARGET PLATE
SEE DETAIL A
1/4" x 1" GALVANIZED
BOLTS WITH LOCK
WASHERS AND NUTS.

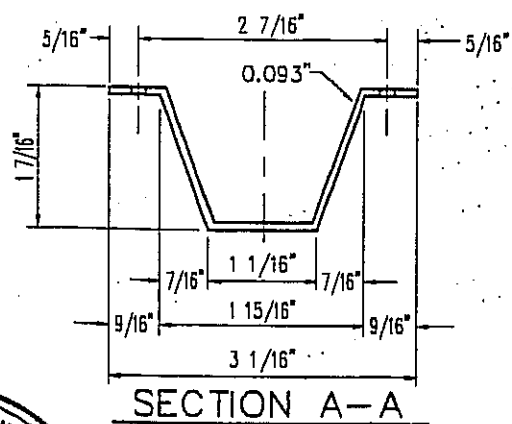
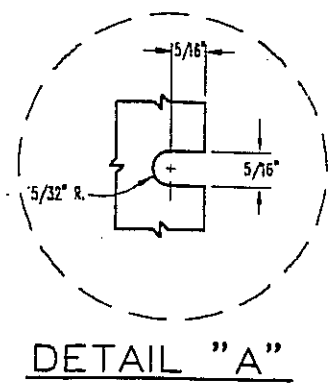

SECTION A-A

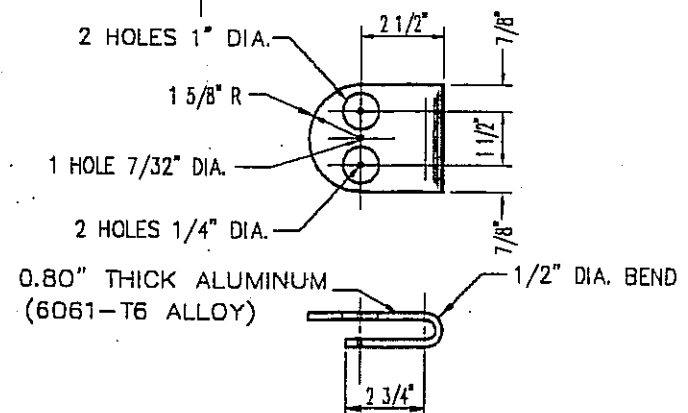

REAR MOUNT BRACKET

NOTES:

1. CLEARANCE MARKER (W-60R) THREE 3-1/4" WHITE CENTERMOUNT REFLECTORS.
2. GUIDE MARKERS ONE 3-1/4" WHITE CENTERMOUNT REFLECTOR.
3. REAR MOUNT REFLECTOR BRACKET SHALL BE USED ON CURVES. BRACKET SHALL BE ATTACHED WITH 3/16" BLIND ALUMINUM RIVETS AND USED TO MOUNT A 3" WHITE REFLECTOR.
4. ALL MATERIALS SHALL CONFORM TO STATE OF CALIFORNIA STANDARD SPECIFICATIONS.
5. HOLE DIAMETERS APPLY TO DIMENSION AFTER ITEM IS PAINTED.

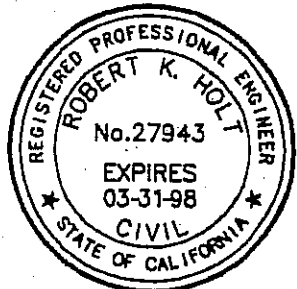

APPROVED: _____ DATE _____

APPROVED: TOWN ENGINEER
Robert K. Holt R.C.E. 27943

REVISION	BY	DATE



Town of
Yucca Valley

TRAFFIC SAFETY
MARKERS

STANDARD DRAWING NO. 520

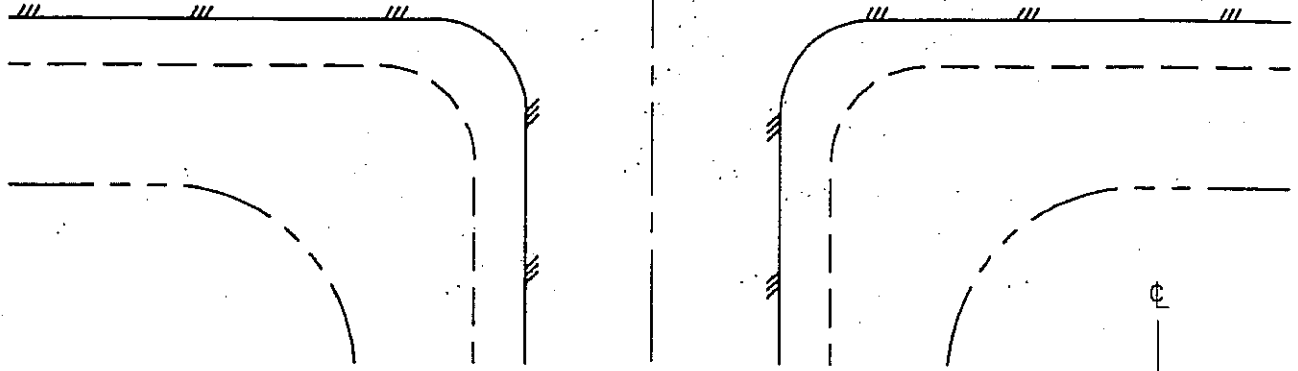
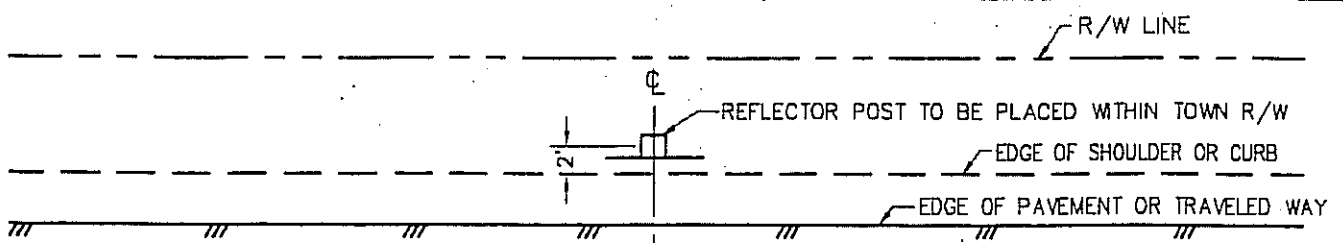

PLAN

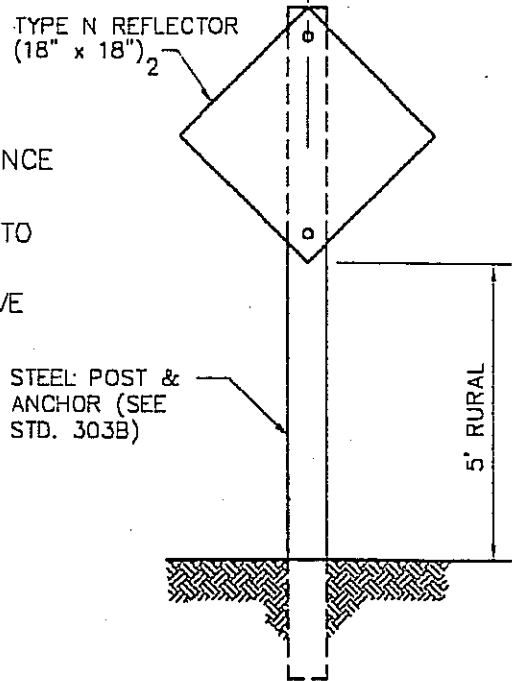

ELEVATION

NOTES:

1. POSTS SHALL BE 2" x 2" SQUARE STEEL IN ACCORDANCE WITH STANDARD NO. 523.
2. MATERIALS AND TYPE N REFLECTOR SHALL CONFORM TO STATE OF CALIFORNIA STANDARD SPECIFICATIONS. TYPE N-4 SHALL BE YELLOW FHWA TYPE III REFLECTIVE SHEETING. TYPE N-5 SHALL BE RED FHWA TYPE III REFLECTIVE SHEETING.

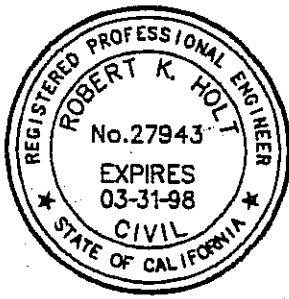

APPROVED: _____ DATE _____

APPROVED: TOWN ENGINEER
Robert K. Holt
 R.C.E. 27943



Town of
Yucca Valley

POST WITH
 REFLECTOR

STANDARD DRAWING NO. 521

REVISION	BY	DATE

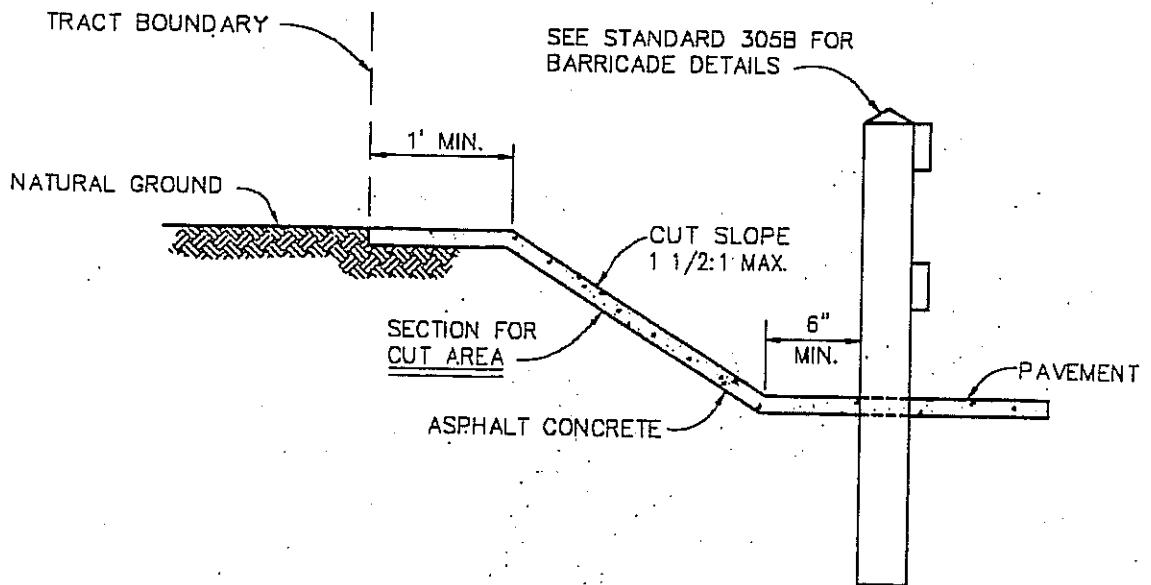

SEE STANDARD 305B FOR BARRICADE DETAILS

SEE STANDARD 522A FOR BARRICADE DETAILS

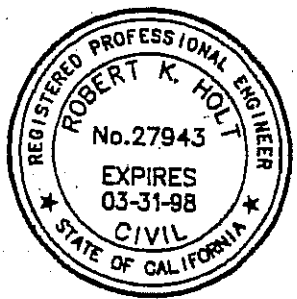
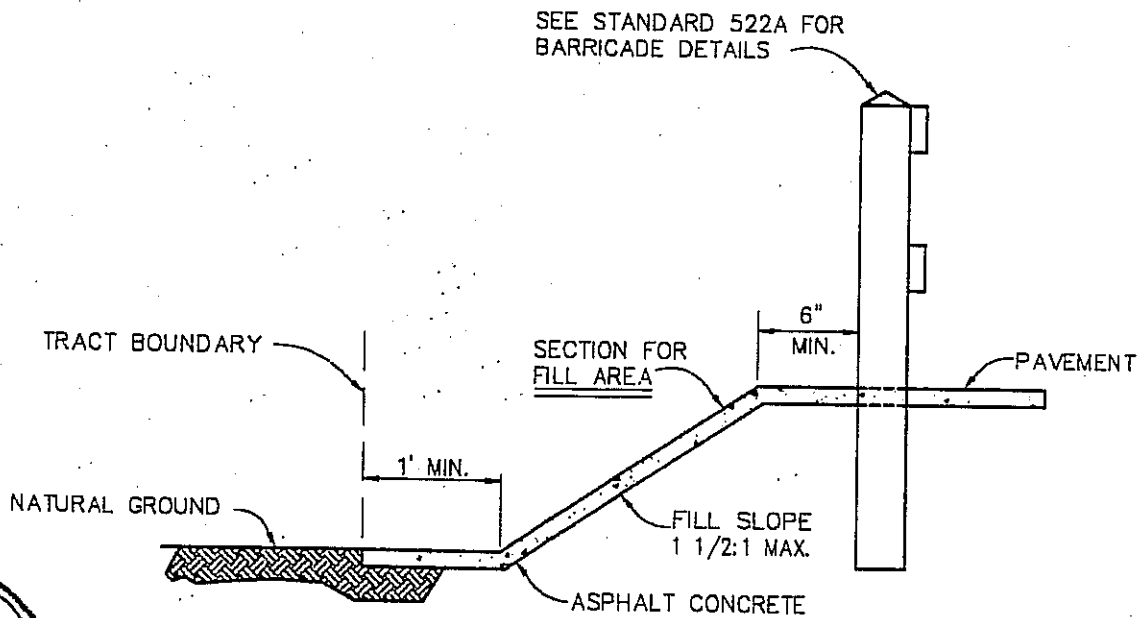

NOTES:

- 1. ASPHALT CONCRETE SHALL BE MINIMUM 3 INCH THICKNESS ON CUT OR FILL AREA.

APPROVED:	DATE
APPROVED: TOWN ENGINEER <i>Robert K. Holt</i>	R.C.E. 27943
REVISION	BY DATE



Town of
Yucca Valley

END OF STREET
TEMPORARY PAVEMENT

STANDARD DRAWING NO. 522

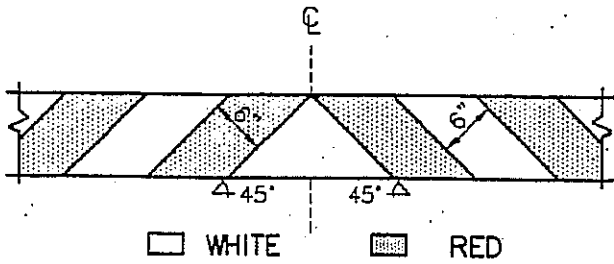
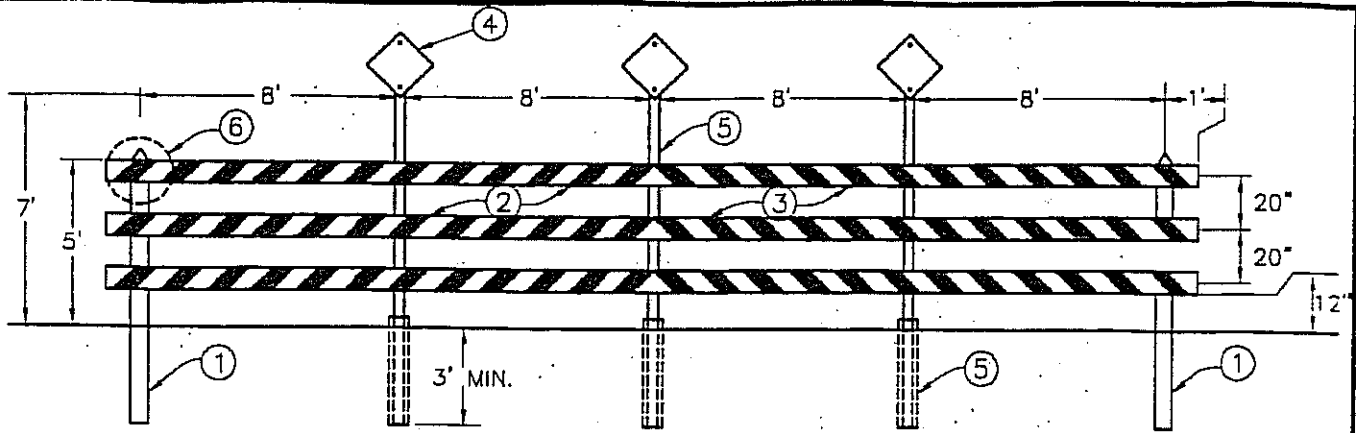

WIDTH OF ROADWAY	NUMBER OF PANELS	NO. OF N2	TOTAL LENGTH OF RAILS
20' ALLEY	2	1	18'
26'	3	2	26'
40'	4	3	38'
46'	4	3	44'
54'	5	4	52'
60'	7	4	58'

③ REFLECTIVE TAPE DETAIL

NOTE: RAILS FACING IN TWO DIRECTIONS, NUMBER OF REFLECTORIZED RAILS SHOULD BE ON TWO FACES.

NOTES:

- ① - POST IS TO BE 6" x 6" x VARIES, TIMBER S.4S.
- ② - THREE (3) CROSS PANELS TO BE 2" x 8" x VARIES, TIMBER S.4S.
- ③ - REFLECTIVE TAPE CONSISTS OF REFLECTIVE DIAMOND GRADE SHEETING WITH HIGH TACK PRESSURE SENSITIVE ADHESIVE, WHITE AND RED TAPE WITH 6" WIDTH (SEE DETAIL ABOVE).
- ④ - OBJECT MARKER RED TYPE N2 SIGN REFLECTOR SHALL CONFORM TO STATE OF CALIFORNIA STANDARD SPECIFICATION AND TO FHWA TYPE IIIA OR VISUAL IMPACT PERFORMANCE (VIP) REFLECTIVE SHEETING. USE A MINIMUM OF TWO (2) SIGNS (SIMILAR TO STD. NO. 521).
- ⑤ - 2" SQUARE STEEL POST AND 2 1/2" SQUARE ANCHOR SLEEVE (SEE STD. NO. 523).
- ⑥ - USE 3/8" DIAMETER, 4 1/4" LONG LAG BOLTS (GALVANIZED) FOR FASTENING ITEM 2 TO ITEM 1 (MINIMUM 4 BOLTS PER CONNECTION).
- 7 - RAILS FACING TRAFFIC TO BE REFLECTORIZED.
- 8 - ALL TIMBER TO BE S.4S. WEATHER RESISTANT.
- 9 - ALL DIMENSIONS ARE NOMINAL LUMBER DIMENSIONS.

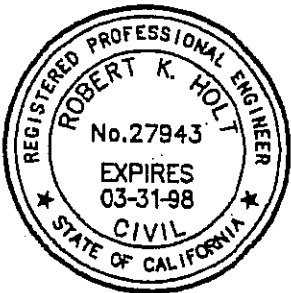

APPROVED:

DATE

APPROVED: TOWN ENGINEER

Robert K. Holt

R.C.E. 27943



Town of
Yucca Valley

BARRICADE
RURAL AREA

REVISION

BY DATE

STANDARD DRAWING NO. 522A

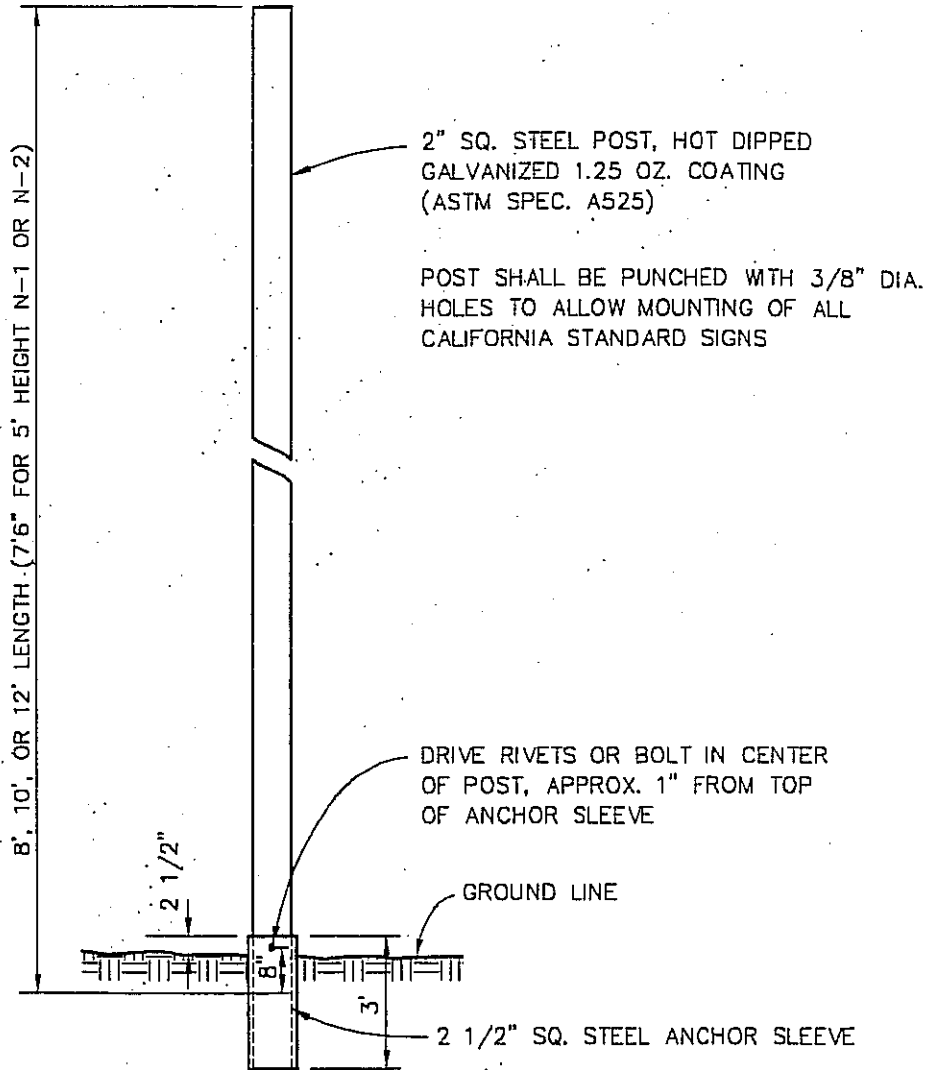

NOTES:

1. SEE STANDARD DRAWING NO. 521 FOR MARKER LOCATIONS.
2. POST SHALL BE 2" SQ. STEEL AS SHOWN AND STATED.
3. ANCHOR SLEEVE SHALL BE 2 1/2" SQ. STEEL HOT DIPPED GALVANIZED AFTER FABRICATION (ASTM SPEC. 1-123).

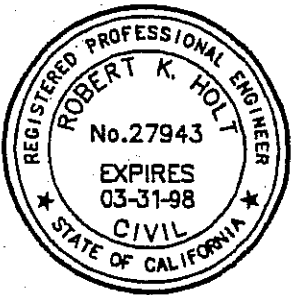

APPROVED:

DATE

APPROVED: TOWN ENGINEER

Robert K. Holt

R.C.E. 27943



Town of
Yucca Valley

STREET MARKER
POST INSTALLATION

STANDARD DRAWING NO. 523

REVISION

BY DATE

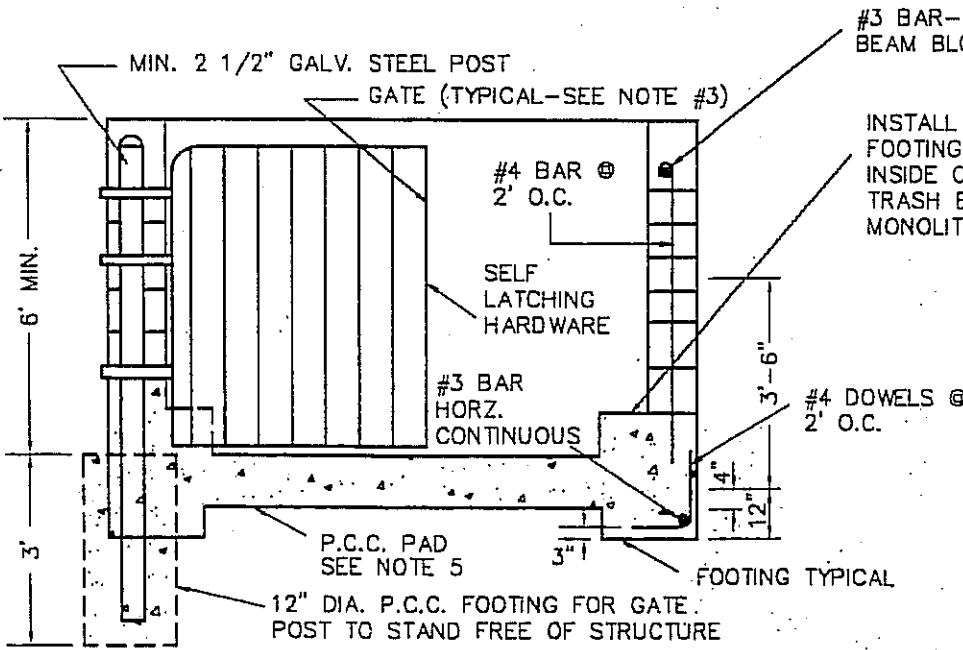

#3 BAR-TOP AND BOTTOM; USE BOND BEAM BLOCKS.

INSTALL (8X8 BARRIER CURB) WITH FOOTING COMPLETELY AROUND INSIDE OF ENCLOSURE TO ACT AS TRASH BIN BUMPER GUARD. POUR MONOLITHICALLY WITH FOOTING.

NOTES:

1. TRASH AREA TO BE LOCATED SO AS TO BE ACCESSIBLE TO BOTH DEPOSIT AND PICKUP. LOCATION TO BE APPROVED BY PLANNING DIVISION.
2. SIX INCH MASONRY BLOCK CONSTRUCTION WITH STANDARD STEEL REINFORCING RODS. FILL ALL CELLS WITH GROUT AND SMOOTH THE TOP WITH STEEL TROWEL FINISH.
3. METAL GATES WITH HEAVY DUTY HARDWARE (TYPICAL). METAL PANEL GATES SHALL TOTALLY OBSCURE THE TRASH BINS AND MUST BE ARCHITECTURALLY COMPATIBLE WITH THE PROJECT.
4. GATE POSTS SHALL BE MINIMUM 2-1/2" DIA. GALVANIZED STEEL SET IN CONCRETE TO STAND FREE OF THE ENCLOSURE STRUCTURE.
5. TOP OF PAD TO BE AT GROUND OR EDGE OF PAVING LEVEL.
6. FILL ALL CELLS WITH P.C.C. PEA GRAVEL GROUT.

FRONT ELEVATION VIEW

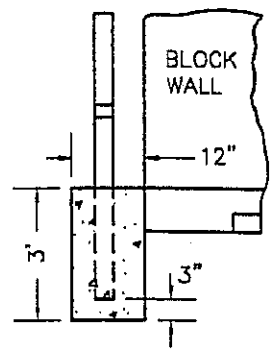
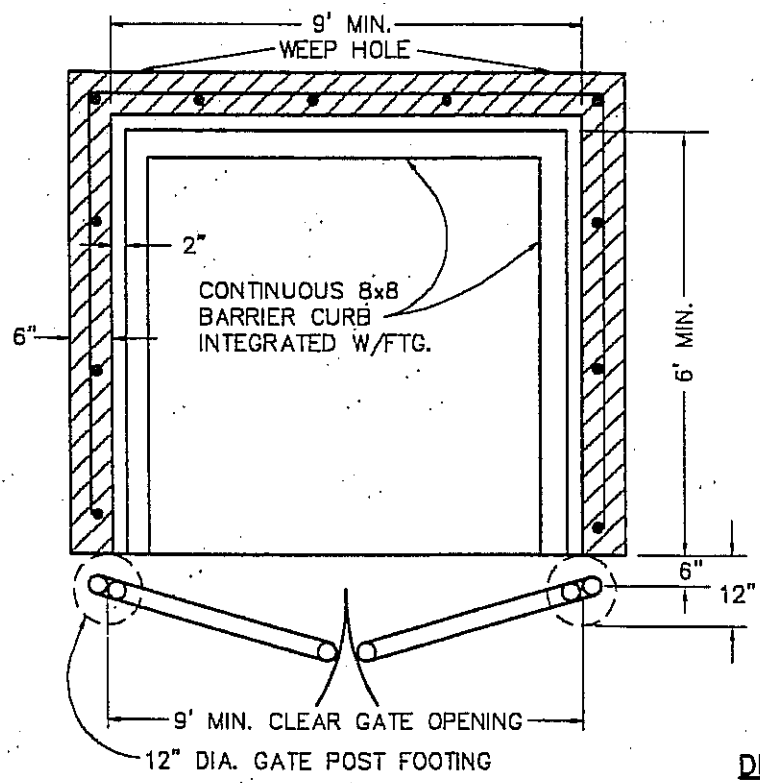

DETAIL - GATE POST FOOTING

PLAN VIEW

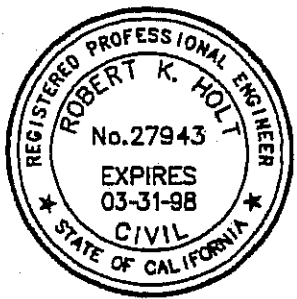

APPROVED: _____ DATE _____

APPROVED: TOWN ENGINEER
Robert K. Holt
 R.C.E. 27943



Town of
Yucca Valley

STANDARD TRASH ENCLOSURE

STANDARD DRAWING NO. 530

REVISION	BY	DATE

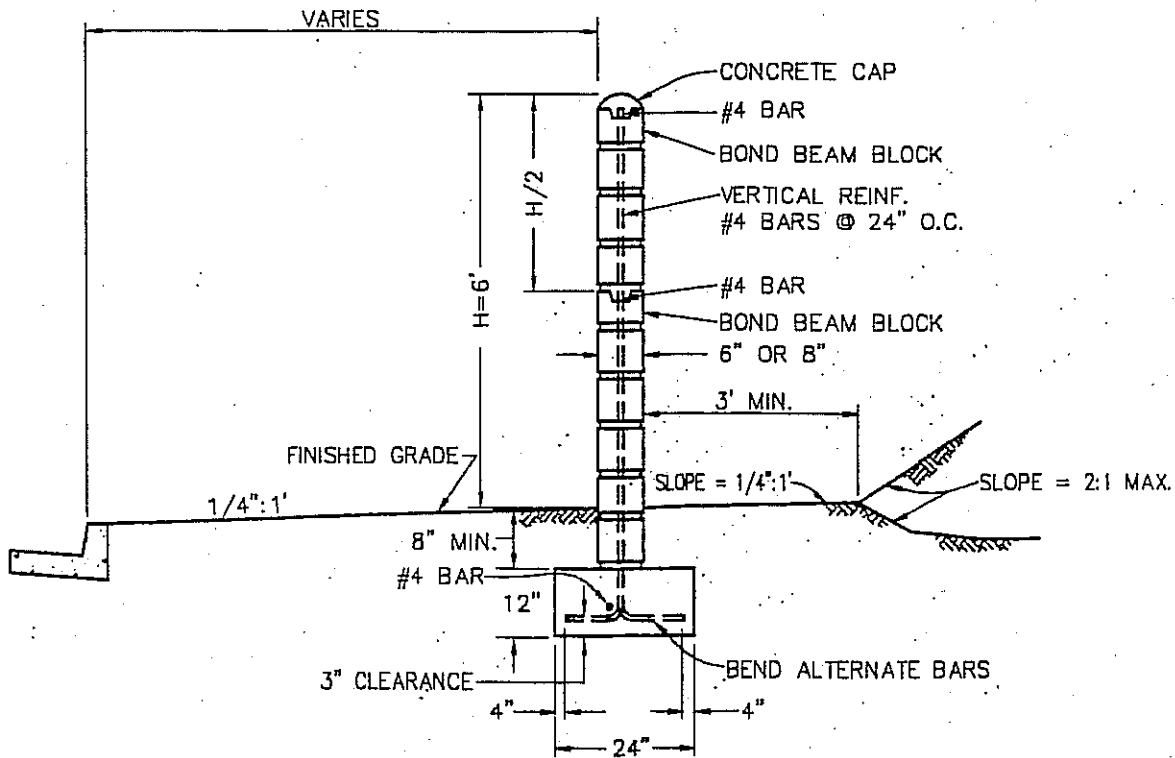

1. ALL VERTICAL CELLS CONTAINING REINFORCING STEEL SHALL BE FILLED WITH GROUT. IN ADDITION, WHERE 6" BLOCKS ARE USED ALL CELLS WITHOUT VERTICAL REINFORCING STEEL SHALL BE FILLED WITH GROUT TO TOP OF BOND BEAM AT MIDHEIGHT OF WALL.
2. THE BLOCK WALL COURSES AND FOOTINGS MAY BE BUILT PARALLEL WITH THE STREET GRADE (7% MAX.) OR STEPPED.
3. ALL WALLS SHALL BE PLUMB.
4. BACKFILL SHALL BE COMPACTED TO A MINIMUM OF 90%.
5. FOOTING SHALL BE CLASS 'B' CONCRETE.
6. CONCRETE BLOCK SHALL BE GRADE A UNITS, CONFORMING TO ASTM DESIGNATION NO. C90
7. REINFORCING STEEL, GROUT MORTAR, AND CLASS 'B' CONCRETE SHALL CONFORM TO THE STANDARD SPECIFICATIONS.
8. ELIMINATE MORTAR IN ALL VERTICAL JOINTS IN FIRST COURSE ABOVE FINISH GRADE.
9. 1/2" OPEN JOINTS EXTENDING THROUGH THE ENTIRE HEIGHT OF THE BLOCK WALL, SHALL BE SPACED AT A MAXIMUM OF 50'.
10. ELIMINATE MID-HEIGHT BOND BEAM IN WALLS WHERE H=4" OR LESS.

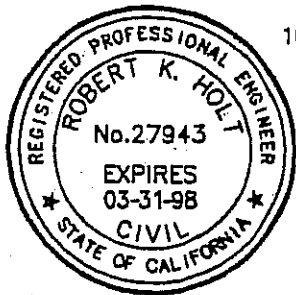

APPROVED:

DATE _____

APPROVED: TOWN ENGINEER

Robert K. Holt

R.C.E. 27943



Town of
Yucca Valley

NON RETAINING
CONCRETE BLOCKWALL

STANDARD DRAWING NO. 540

REVISION

BY DATE

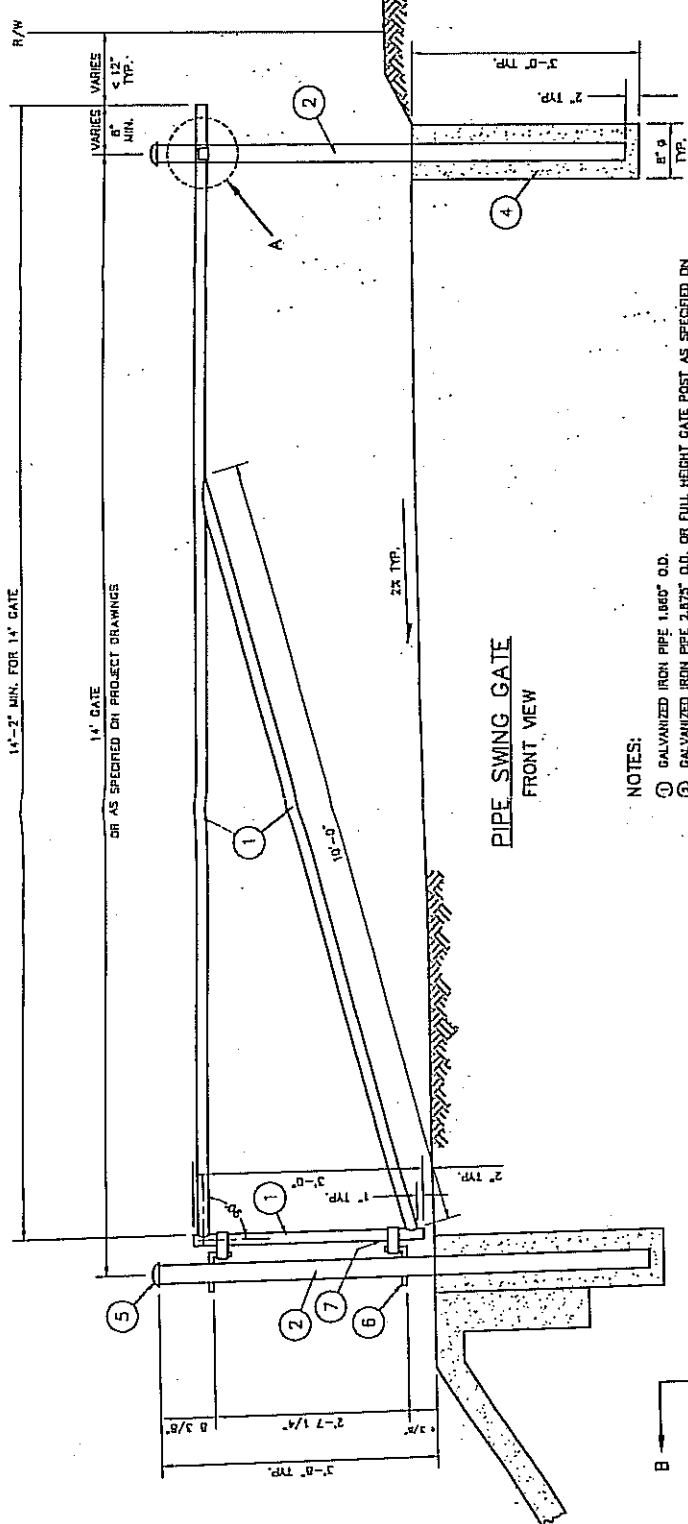

NOTES:

- 1 GALVANIZED IRON PIPE 1.660" O.D.
- 2 GALVANIZED IRON PIPE 2.875" O.D. OR FULL HEIGHT GATE POST AS SPECIFIED ON PROJECT DRAWINGS.
- 3 GATE REST, ONE-HALF OF GALVANIZED IRON PIPE 2.375" O.D.; GRIND TO FIT VERTICAL POST, FIELD WELD.
- 4 CLASS "B" CONCRETE.
- 5 POSTS ANCHORED IN CONCRETE SHALL HAVE CAPS.
- 6 HINGE BOLTS 5/8", WELD THREADED END AFTER INSTALLATION.
- 7 STANDARD HINGE CLAMPS, WELD THREADED END OF BOLTS AFTER INSTALLATION.
- 8 3/8" GALVANIZED CHAIN, FELD WELD ONE LINK TO VERTICAL POST, PROVIDE OPENING IN LINKS OR HATCHES AS SHOWN. CHAIN SHALL BE OF SUFFICIENT LENGTH TO ENCLOSE HORIZONTAL PIPE.
- 9 ENDS OF PIPES TO BE JOINED SHALL BE GROUNDED TO FIT NEATLY BEFORE WELDING.
- 10 MATERIALS AND CONSTRUCTION METHODS SHALL CONFORM TO THE APPLICABLE PORTION OF SECTIONS 200-6, 210-3 AND 304-3 OF "STANDARD SPECIFICATIONS FOR PUBLIC WORKS CONSTRUCTION", LATEST EDITION.

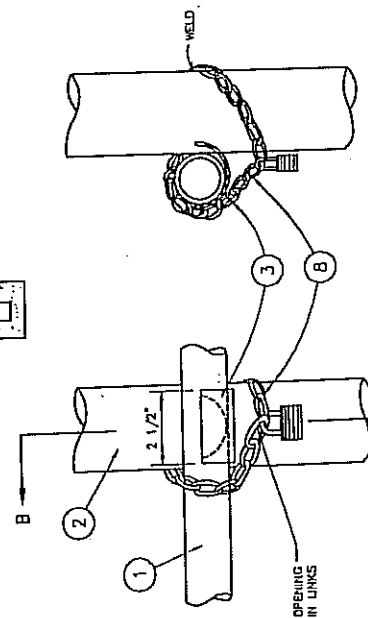

DETAIL A

SECTION B-B

APPROVED: _____ DATE _____

APPROVED: TOWN ENGINEER
Robert K. Holt R.C.E. 27943

REVISION	BY	DATE

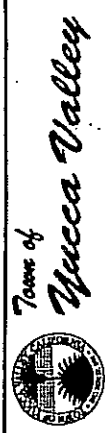
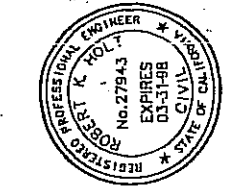

PIPE SWING GATE

STANDARD DRAWING NO. 550

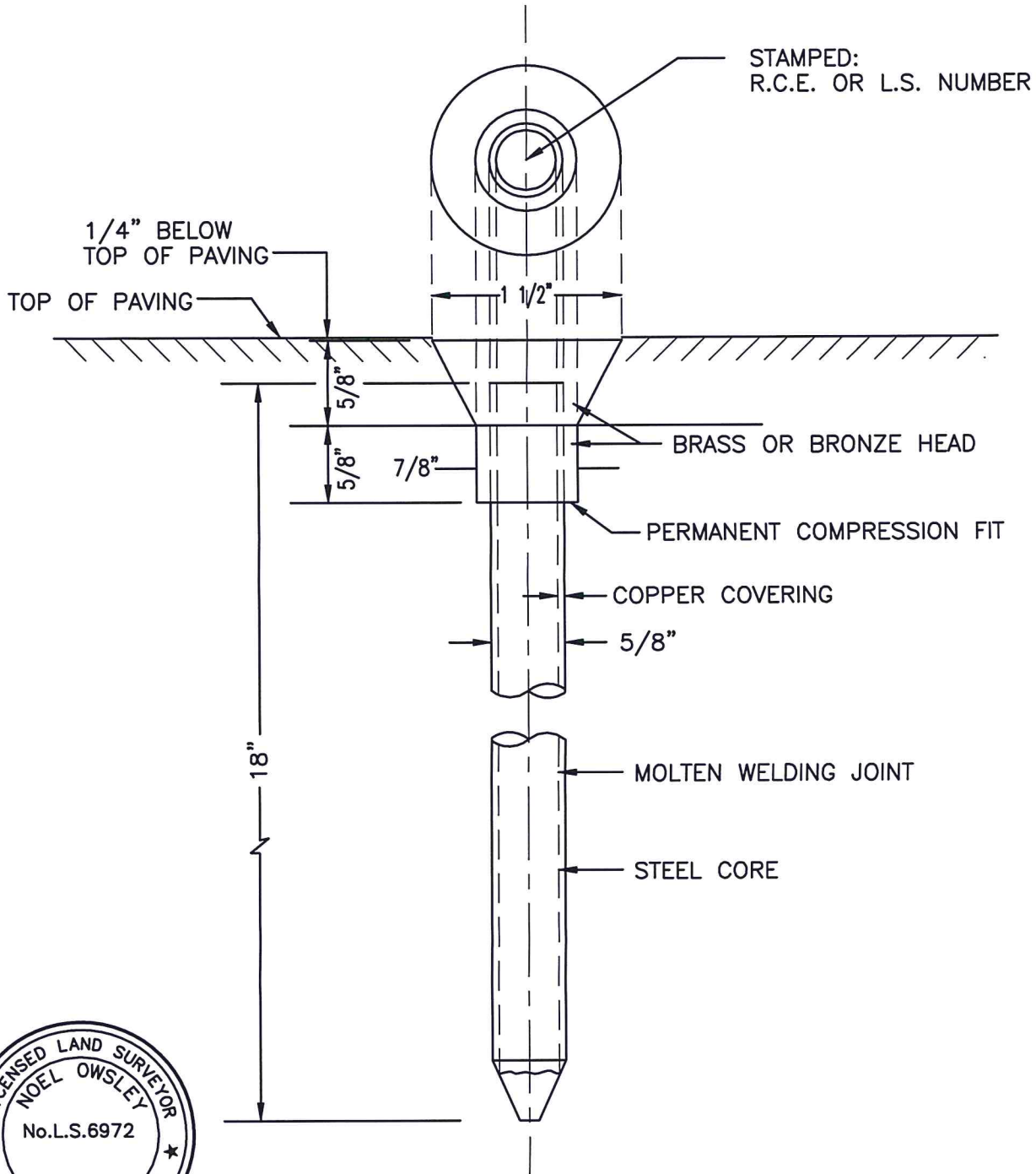

APPROVED: Alex Bishka DATE 6/29/16

APPROVED: TOWN SURVEYOR
Noel Owsley L.S. 6972



Town of
Yucca Valley

COPPERWELD MONUMENT

STANDARD DRAWING NO. M1

REVISION	BY	DATE

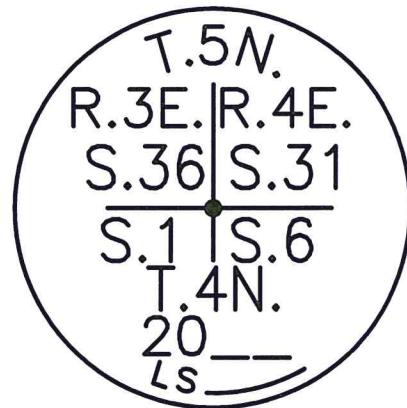
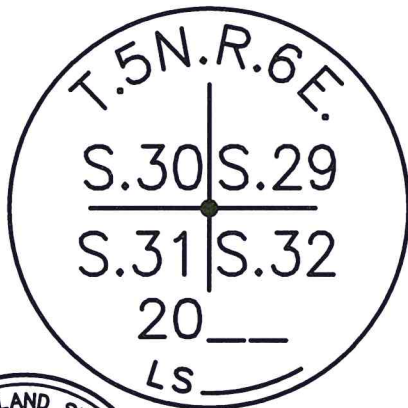
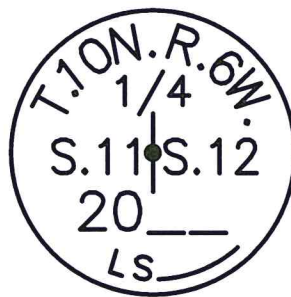
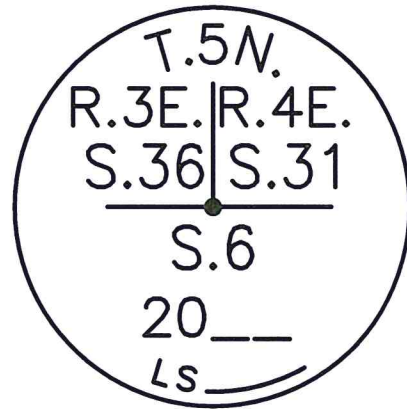
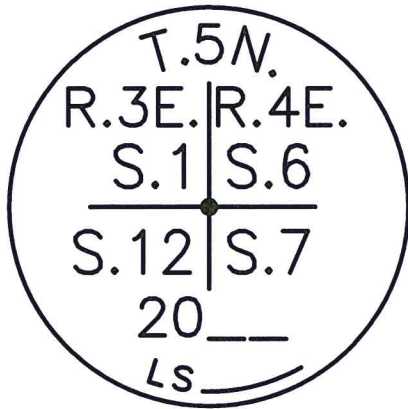

APPROVED: Alex Oishi DATE 6/29/16

APPROVED: TOWN SURVEYOR
Noel Owsley L.S. 6972

REVISION	BY	DATE



Town of
Yucca Valley

SECTIONAL MONUMENTS

STANDARD DRAWING NO. M2

NOTES:

On curves where the P.O. falls outside of the paved section or curbed section, monuments may be set and tied out on semi-tangents in lieu of B.C., E.C. a Mid-point being tied out. These monuments will be set within traveled way.

- Indicates set 1" I.P. with tag or alternate monument (i.e. tag in P.P., tag in wall footing, etc.)
- Indicates set copperweld
- Indicates set lead and tack with tag in curb.

Tags set as reference points shall be labeled "RP" and include the L.S. or RCE number.

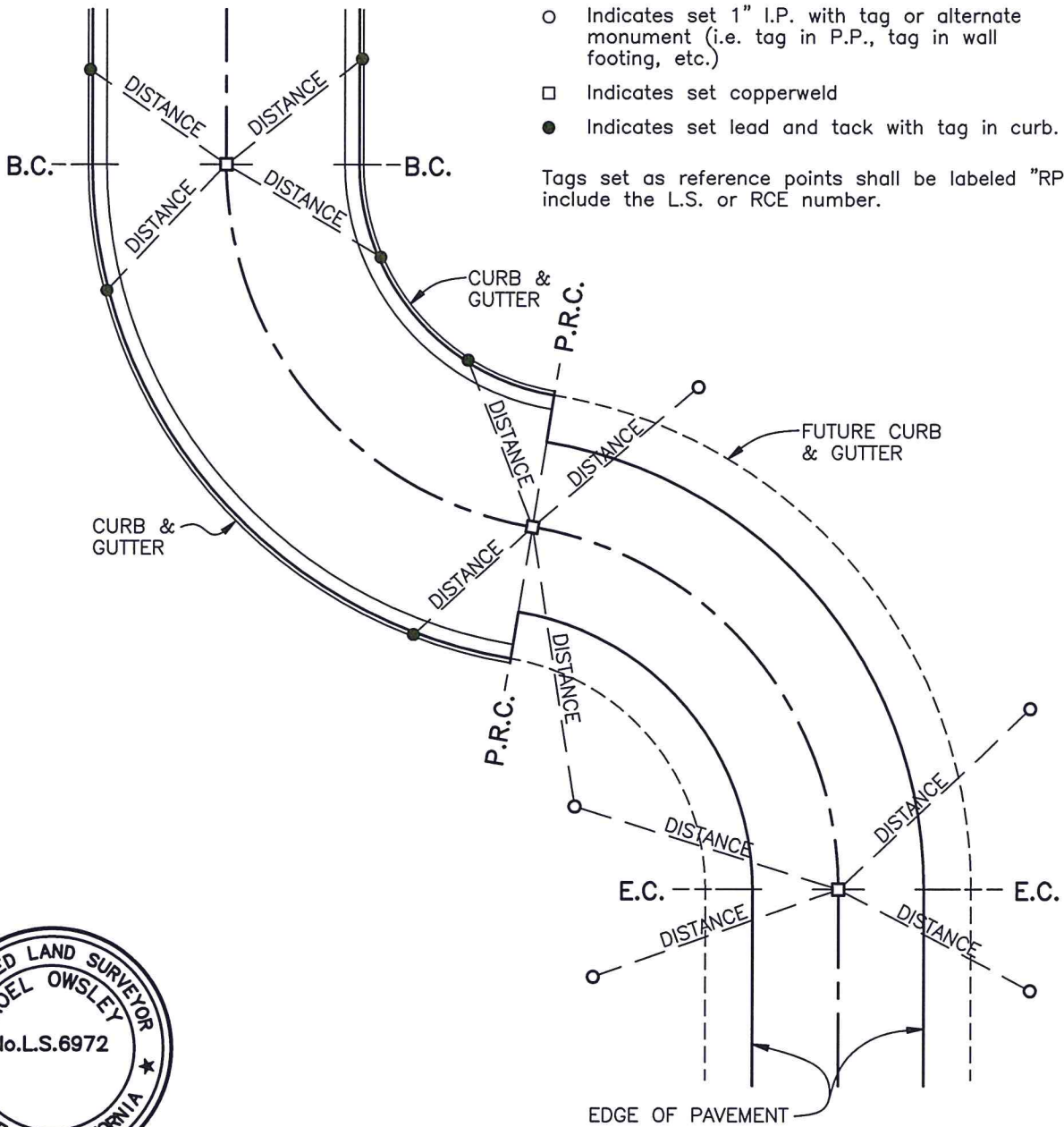

APPROVED:

Alex Oishi DATE 6/29/16

APPROVED: TOWN SURVEYOR

Noel Owsley L.S. 6972



Town of
Yucca Valley

CENTERLINE TIES

STANDARD DRAWING NO. M3

REVISION

BY DATE